

Platinum Home & Contents Insurance

Product Disclosure Statement

WE COVER DETAILS



Find your way through this document

Introduction	4
Welcome to GIO Platinum Home & Contents Insurance	4
Summary of major cover	5
About your sum insured	6
About your premium	7
Paying your premium	8
Proof of ownership and value	8
About your cover	9
What we cover as your home	9
What we do not cover as your home	9
Limits on home cover	10
What we cover as your contents	11
What we do not cover as your contents	12
Where your contents are covered	13
Limits on contents cover	14
How much contents cover do you need?	16
What you are covered for	17
Additional features	18
Optional covers	37
What you are not covered for	39
Claims	51
Making a claim	51
Definition of proofs	52
Minimum proofs of ownership and value	53
How to establish your loss	57
Your excess	58
How we settle your claim	59
Home claims	61
Contents claims	66
Does your claim affect your cover	67
What we will do after a claim is paid	68
More details	68
Other Important Information	69
Your responsibilities	69
When you need to call us	69
What happens with cancellations?	70
Terms explained	71
If you have a complaint	75
Report insurance fraud	75
General Insurance Code of Practice	76
Financial Claims Scheme	76

Introduction

Welcome to GIO Platinum Home & Contents Insurance

Why is this document important?

This Product Disclosure Statement (PDS) is an important legal document that contains details of your home and contents insurance. Before you decide to buy insurance from us, please read this PDS through and then keep it, together with your certificate of insurance, in a safe place.

The information in this PDS was current at the date of preparation. We may update some of the information in the PDS that is not materially adverse from time to time without needing to notify you. You can obtain a copy of any updated information by contacting us on **13 10 10**. We will give you a free paper copy of any updates if you request them. If it becomes necessary, we will issue a Supplementary PDS (SPDS) or replacement PDS.

Cooling off period

After you take out this insurance or renew your policy for another period of insurance, you have **21** days to consider the information in your PDS. This is called the cooling off period. If you wish, and provided you have not made a claim, you can cancel your insurance within **21** days from the day cover began or was renewed. We will then refund in full any money you have paid.

Who is this product designed for?

This insurance product is specially designed to provide cover for quality homes and contents. If you live in a house, unit, apartment or flat, you can choose a policy depending on your circumstances and what you want to cover. Minimum levels of sums insured apply – please ask us for details.

This policy does NOT insure investment homes or contents in investment units e.g. a home or unit let to your tenants. Instead, you can choose to apply for our Investor Home & Contents Insurance.

Your full and correct disclosure of facts

You must comply with the duty of disclosure (see meaning on page 72) when you apply for this insurance. We will ask you for information about your home, your contents and yourself, which is used by us to consider your insurance application and calculate your premium. You must answer our questions honestly and tell us anything you or a reasonable person in the circumstances would include in their answer. Your answers apply to you and anyone else to be covered by the policy.

More than one named insured

If there is more than one named insured on your certificate of insurance, we will treat a statement, act, omission, claim or request to alter or cancel your policy made by one as coming from all those named as insured on your certificate of insurance.

Summary of major cover

Accidental loss or damage

Your home and contents are covered for accidental loss or damage at the insured address. Some examples of what accidental loss or damage also includes are shown below.

This summary must be read together with the terms and conditions set out in this PDS.

Examples of accidental loss and damage



Fire

but we do not cover damage caused by scorching, ash or soot when your home has not caught on fire.



Theft and damage caused by thieves

but we do not cover theft by people you invite into your home.



Storm and flood

but we do not cover damage caused by actions of the sea or damage to retaining walls.



Malicious damage, vandalism and riot

but we do not cover damage by someone who lives at the home.



Lightning

but we do not cover damage caused by power failures or surges by your power provider.



Explosion

but we do not cover repairing or replacing the tank that has exploded.



Earthquake and tsunami

but we do not cover subsidence damage that occurs more than 72 hours after the earthquake.



Impact by motor vehicles, aircraft, trees and power poles

but we do not cover the removal of dangerous trees around your home.



Leaking or bursting of liquid from pipes or tanks

but we do not cover the repair of a leaking shower base.



Damage by animals

but we do not cover damage by biting, chewing, pecking or clawing.

About your sum insured

What is a sum insured?

The sum insured is the most you can claim for any one incident. The amount is shown on the certificate of insurance or in this PDS. The sum insured includes GST and any adjustment you are entitled to under additional feature 21 (automatic adjustments to the sum insured) on page 36.

Make sure your sum insured is adequate

Underinsurance can expose you to serious financial loss if a claim occurs. Make sure your home and contents are insured for their full new for old replacement value and it is your responsibility for deciding the amount of your sum insured.

Review your sum insured regularly

To ensure your sum insured is adequate, it is important to review it regularly and ask us to change the sum insured when required.

New replacement prices are constantly changing, especially for jewellery, valuables, photographic, computer, audio and visual electronic goods.

If you upgrade the size and standard of your home, it may increase the cost to rebuild your home. Your sum insured will need to reflect these types of changes.

If you over-insure

We will not pay more than it costs us to rebuild, repair or replace.

We will not refund any premium overpaid for over-insuring so it's a good idea to constantly review your sums insured.

Goods and Services Tax (GST)

Sums insured, limits and the most we pay stated in this PDS and on your certificate of insurance include GST.

About your premium

The premium is the amount you pay us for this insurance. You also pay stamp duty, GST, any government charges and fire services levy that applies.

In addition to your sum insured, we use many factors about you and your home and contents to work out your premium. These are called premium factors. The premium factors we use reflect the likelihood of you making a claim together with other factors related to our cost of doing business.

Each time you renew your insurance your premium is likely to change, even if your personal circumstances have not changed. This is because premiums are affected by other things such as our expenses of doing business and changes in our approach to how we calculate your premium.

In addition to the factors we use to calculate your premium, the discounts you qualify for also affect your premium. Your premium includes any discounts you qualify for and these are applied before adding applicable government charges.

More details

For further details on how we work out your premium and for information about the discounts you may be eligible for, please refer to our Premiums, Excesses, Discounts and Claim Payments Guide available at gio.com.au/moredetails. A copy of this guide can be provided to you on request, at no charge, if you contact us on 13 10 10.

Paying your premium

We will tell you how much you have to pay and how much time you have for payment on your certificate of insurance. You must pay the premium by the due date to be covered by this policy.

Unless we tell you, any payment reminder we send you does not change the expiry or due date. If you do not pay the premium and other charges in full, we may reduce the period of insurance so it is in line with the amount you paid.

You can pay your premium in one annual payment or by monthly instalments.

Paying premiums annually

If you do not pay your premium by the due date, we will give you a written notice of policy cancellation where we are required at law to do so.

If you pay your premium late, we may reject your payment and your policy will cease from the due date. If we accept your late payment, we might re-commence your cover from the date we receive your payment. If so, you will have no cover for the period from the due date until the date of payment.

Paying premiums monthly

If you pay your premium by monthly instalments and your payment is overdue, we can:

- › refuse to pay a claim if payment is **14** days (or more) late **and**
- › cancel your policy without notifying you if payment is **1** month (or more) late.

If you pay by the month we charge a fee of **\$3.50** each month as part of your premium and this is included in your monthly payment.

Proof of ownership and value

When you make a claim we may ask you to give us proof of ownership and value for what you are claiming for. This is especially important for valuables and items listed on your policy, as well as electrical appliances and furnishings.

We understand it is not practical to keep proofs for every household item you own. However, there are some items where we will reduce or refuse a claim unless you have proof of ownership and value. For full details refer to pages 53 to 57.

About your cover

What we cover as your home

Your home means your residential building at the insured address including its structural improvements, fixtures, fittings and domestic outbuildings.

Home also includes:

- › fixed wall coverings such as paint, wallpaper and wall tiles
- › fixed floor coverings including lino (glued down or not), timber floor coverings, **but not carpet or rugs** (carpet and rugs are covered under contents)
- › dishwashers housed in a cabinet (mobile dishwashers are covered under contents)
- › fixed or ducted air conditioners or vacuum systems (air conditioners attached to windows are covered under contents)
- › electrical and gas appliances, light fittings and alarm systems if these appliances are permanently connected or plumbed to the electricity or gas supply
- › fixed swimming pools and spas and their accessories
- › service pipes or cables you own or are legally responsible for
- › garden borders, paths and paving
- › boat jetties and pontoons
- › driveway or road surfaced with bitumen (limits apply)
- › walls, gates and fencing (limits apply)
- › unfixed home building materials and uninstalled home fittings (limits apply).

What we do not cover as your home

Home does not include:

- › any domestic outbuilding occupied as a residence with its own electric metering
- › chemicals, fertilisers and pesticides that have been used or applied
- › lawns, trees, shrubs, plants, hedges for more than they are covered under additional feature 14
- › a caravan, motor vehicle, motor cycle, trailer, mobile home, tent, rail carriage, tram, aircraft or watercraft
- › inflatable swimming pools or portable spas
- › a hotel, motel, boarding house or guest house
- › water in tanks, swimming pools, spas or any other water container
- › carpet (fixed or unfixed) or floor rugs
- › loose or compacted soil, earth, gravel, pebbles, rocks or granular rubber (e.g. sand on tennis courts or gravel driveways), **but we will pay** the cost to restore soil or earth to the extent that it is necessary to repair insured damage to your home.

Limits on home cover

The most we will pay for any one insured incident is the sum insured shown on your certificate of insurance unless a limit applies in the table below. You cannot increase the limits.

Fixed limits apply to:	Limits for any one insured incident
Unfixed home building materials and uninstalled home fittings (e.g. tiles stored in the shed or an oven that is not yet installed)	up to \$2,000
Fencing	up to 2 kilometres
Bitumen surfaced driveway or roadway	up to 500 metres
Options	The amount or limit shown for that option (see pages 37 to 38)
Additional features	The amount or limit shown for that additional feature (see pages 18 to 36)

What we cover as your contents

Your contents means your furniture, furnishings, unfixd electrical goods, valuables, portable personal possessions, clothing and unfixd household goods that you own.

Contents also includes:

- › carpet and rugs (fixed and unfixd)
- › internal blinds and curtains
- › wheelchairs and mobility scooters
- › household tools and gardening equipment including ride-on mowers
- › mobile dishwashers
- › plants in pots
- › food and medicines
- › inflatable or portable swimming pools and portable spas and their accessories
- › surfboards, sailboards, canoes, kayaks and non-motorised surf skis
- › remote-controlled model or toy:
 - › motor vehicles
 - › aircraft with a wing span up to **1.5** metres
 - › watercraft
- › contents items that you are legally responsible to insure under a written contract (e.g. a hire agreement but not a tenancy rental agreement)
- › your fixtures and fittings installed in a home that you rent.

If contents are insured in a unit

Contents also includes your fixtures and fittings in a unit which are not insured by the unit building policy according to state regulation. For example:

- › wall paint and paper if your unit is located in NSW
- › lino if it is not stuck down
- › floating wooden floors paid for by you after the building was built
- › air conditioners and spas for the sole use of the unit owner or occupier
- › fixtures owned by you as a tenant which will be removed when vacating.



What we do not cover as your contents

Contents does not include:

- electrical and gas appliances, light fittings, alarm systems permanently connected or plumbed to the electricity or gas supply
- air conditioners that leave a hole in a wall if removed
- dishwashers housed in a cabinet
- chemicals, fertilisers and pesticides that have been used or applied
- plants not in a pot
- lawns, trees, shrubs, hedges unless covered under additional feature 14
- fixed swimming pools or spas and their accessories
- water in tanks, swimming pools, spas or any other water container
- animals including fish, reptiles, pets and livestock
- stock for a past, present or future business activity
- travel or other tickets, coupons or gift vouchers
- unfixed home building materials and uninstalled home fixtures or fittings
- loose or compacted soil, earth, gravel, pebbles, rocks or granular rubber (e.g. sand on tennis courts or gravel driveways)
- motor vehicles, motor cycles, mini-motor cycles or motorised bicycles and their accessories other than those covered under additional feature 16
- caravans, mobile homes or any of their contents
- trailers, horse floats or horse-drawn carriages
- aircraft other than remote controlled models or toys with a wing span less than **1.5** metres
- watercraft other than surfboards, sailboards, canoes, kayaks and non-motorised surfskis.

Where your contents are covered

The table below shows the cover we provide in different locations.

At the home	Elsewhere in Australia and New Zealand	Elsewhere in the world (for listed jewellery and watches* only)
 <p>This policy covers your contents at the home.</p> <p>However, fixed and flexible limits apply to some items (e.g. the most we will pay for jewellery is \$5,000 per item). You can increase cover for items and other valuables with flexible limits see pages 15 to 16.</p>	 <p>We will cover your contents anywhere in Australia or New Zealand for up to 185 days when they are temporarily away from the insured address but we will not cover the items shown below.</p>	 <p>We will cover jewellery and watches listed under your contents policy when they are outside Australia and New Zealand for up to 100 days but only when these items are:</p> <ul style="list-style-type: none">➤ being worn by you or➤ secured in a safe. <p>See page 16 for full details on listing your contents items.</p>

Things that are not covered when elsewhere in Australia and New Zealand

We will not cover loss or theft of, or damage to:

- cash or documents able to be cashed
- tools of trade
- any contents on exhibit or up for sale, such as wine at an auction, artworks on display in a gallery
- accessories to any:
 - motor vehicle, motor cycle or trailer
 - powered watercraft
 - sailing craft unless it is an accessory to a sailboard
 - aircraft unless it is an accessory to a model aircraft with a wingspan no longer than **1.5** metres
- contents being packed, carried or transported from your current insured address to a new address on a permanent basis but some incidents are covered by additional feature 12a.

Things that are not covered when elsewhere in Australia and New Zealand

We will not cover theft of:

- › watercraft e.g. a surfboard, wave board, sailboard, canoe, kayak or surf ski, when in a public place unless at the time of the theft it was locked:
 - › inside a motor vehicle or inside a roof box carrier on a motor vehicle
- › bicycles in a public place unless at the time of the theft it was locked:
 - › to a fixed object
 - › to a rack or carrier attached to a motor vehicle
 - › inside a motor vehicle.

Limits on contents cover

The most we will pay for any one insured incident is the sum insured shown on your certificate of insurance. However, for some items, we will only pay up to the limits shown in the following tables. There are two types of limits: fixed and flexi-limits.

Fixed limits

Items below have fixed limits and the **limits cannot be increased**.

Fixed limits apply to:	Limits for any one insured incident
Home office equipment	up to \$20,000 in total
Tools of trade and equipment used for a business activity (not 'home office equipment')	up to \$5,000 in total
Refrigerated or frozen food and medicines	up to \$2,000 in total
Uncut and unset gems, gold or silver nuggets and ingots (not jewellery)	up to \$1,000 in total
Cash, smart cards, phone cards and documents able to be cashed	up to \$500 in total
Options	the amount or limit shown for that option (see pages 37 to 38)
Additional features	the amount or limit shown for that additional feature (see pages 18 to 36)

Flexi-limits

Flexi-limits are shown in the table below. You can choose either Essential or Essential Plus limits for your cover. Essential limits will apply unless you ask us for Essential Plus and you pay the extra premium that applies. Your choice of Essential or Essential Plus will be shown on your certificate of insurance.

Limits apply to:	Limits for any one insured incident	
	Essential limits	Essential Plus limits
Jewellery and watches	up to \$5,000 for each item or set, but no more than \$20,000 in total	up to \$10,000 for each item or set, but no more than \$40,000 in total
Silver or gold items, items plated with silver or gold unless limited elsewhere in 'contents limits'	up to \$50,000 in total	up to \$100,000 in total
Paintings, pictures, works of art, sculptures and art object	up to \$100,000 in total	up to \$200,000 in total
Stamps, stamp collections, collector's pins, medals and collector's non-negotiable currency	up to \$25,000 in total	up to \$50,000 in total
Collections and memorabilia (Note – wine is not a 'collection' and has no special limit)	up to \$25,000 in total	up to \$50,000 in total

If you own items or valuables above the flexi-limits

You can apply to insure individual items if you own:

- › individual items worth more than the flexi-limits or
- › a number of items in the same flexi-limits category with a total value more than the flexi-limits.

For example

If you have Essential limits and you own:

- › a jewellery item worth \$10,000, you can list this item individually for \$10,000. The flexi-limit of \$5,000 per item and \$20,000 in total will apply to all other jewellery you own.
- › 3 paintings worth \$50,000 each, with a total value of \$150,000, and want more cover than the \$100,000 flexi-limit. You can list one of the paintings with a value of \$50,000 to give yourself \$150,000 cover in total for paintings.

Listing items individually

Steps	What to do	
1	Obtain an Australian valuation and proof of ownership for each item, set or collection to be insured.	You will need an Australian valuation. We might ask to see this before we accept cover.
2	Ask us to insure each item, set or collection and pay us the extra premium that applies.	If we agree to insure the item, it will be shown on your certificate of insurance. You must install extra burglary security and extra fire protection if we ask for this.
3	Keep valuations and proofs of ownership safe from theft, fire and other loss or damage. You will need to show us these if you make a claim.	For safe storage you may consider using a fireproof security box (available from some hardware retailers) or a bank safety deposit box or another safe place of your choice.

How much contents cover do you need?

Contents sum insured

You should insure your contents for the amount it costs to replace all your contents new for old. This amount is called your contents sum insured.

Some key points

Always use current prices to calculate your sum insured, not the depreciated value. This especially applies to items that are old, purchased secondhand or no longer available.

For electronic and hi-tech items

Since the prices of these items are constantly changing, the original purchase price may not be an accurate figure for the sum insured. Choose a sum insured that covers the cost to replace the technology in current prices (e.g. if a camcorder was purchased 5 years ago for \$1600 and may now be replaced for \$600, the sum insured is \$600).

For secondhand purchases

Since we replace these items new, regardless of their age or condition, insure them for the cost to replace them new in current prices. Do not insure them for the secondhand purchase price or the depreciated value.

For obsolete items

Since an obsolete item is no longer available, insure it for the cost to replace it with an item of a similar standard (e.g. if an old colour television is now obsolete, insure it for the cost to replace it with a base model in the next generation of technology with the same size screen).

What you are covered for

You can choose to insure your home and contents, or just home or just contents. Your certificate of insurance will show what covers you have.

Home cover

When you have home cover, your home is covered for accidental loss or damage which happens at the insured address and in the period of insurance, subject to the terms, conditions and limits in this policy.

Accidental loss or damage includes loss or damage from incidents you did not intend to happen, e.g. accidentally breaking kitchen tiles, scorching a bench top or breaking a window.

Contents cover

When you have contents cover, your contents are covered for accidental loss or damage which happens in the three locations shown in 'Where your contents are covered' (see page 13) and in the period of insurance, subject to the terms, conditions and limits described in this policy.

Accidental loss or damage includes loss or damage from incidents you did not intend to happen, e.g. accidentally staining carpet, breaking a glass table top or damage caused to a painting accidentally falling off the wall.

Accidental damage

Accidental loss or damage also includes loss or damage from incidents such as:

- › fire
- › storm and flood
- › lightning
- › earthquake and tsunami
- › leaking or bursting of liquid from pipes or tanks
- › theft and damage caused by thieves
- › malicious damage, vandalism and riot
- › explosion
- › impact by motor vehicles, aircraft, trees and power poles.

There are some incidents we do not insure and these are shown:

- › as 'We do not cover' in additional features and optional covers on pages 18 to 38
- › as 'What you are not covered for' on pages 39 to 50.

More details

For examples on how a claim payment might typically be calculated, please refer to our Premiums, Excesses, Discounts and Claim Payment Guide available at gio.com.au/moredetails. A copy of this guide can be provided to you on request, at no charge, if you contact us on 13 10 10.

Additional features

When we accept a claim under your policy for an insured incident that happens in the period of insurance, you may also be entitled to these additional features.

1a. Temporary accommodation costs when you have home cover

We cover	<p>When you have home cover and an insured incident damages your home to the extent you cannot live there, we will pay for your temporary accommodation costs for the time it takes to repair or rebuild your home to a liveable condition.</p> <p>We will pay:</p> <ul style="list-style-type: none">› up to 2 weeks in short term accommodation agreed to by us (e.g. standard rates for a hotel, motel or serviced apartment), then if necessary:› up to another 50 weeks in residential accommodation of a similar standard to your home. The amount we will pay is based on the weekly rent you would receive for your home had it not been damaged. We will ask a licenced local property manager to assess this amount. <p>The limit for temporary accommodation is 10% of your home sum insured and the longest period you can claim for is 52 weeks. We will pay this in addition to the home sum insured.</p>
We do not cover	<p>Temporary accommodation costs:</p> <ul style="list-style-type: none">› if you were not living in the home at the time of the loss or damage› if damage to the contents is the reason why you cannot live there› if you did not intend to live at your home during the repair period had your home not been damaged› if you do not intend to repair or rebuild your home› if you do not need to pay for the temporary accommodation› beyond the period it should reasonably take to replace or repair your home so you can live there again› if before the insured incident, you had planned to demolish your home.

More details

For further details about how we pay claims under additional feature 1a. Temporary accommodation costs when you have home cover and additional feature 20. Legal liability cover, please refer to our Premiums, Excesses, Discounts and Claim Payments Guide available at gio.com.au/moredetails. A copy of this guide can be provided to you on request, at no charge, if you contact us on 13 10 10.

1b. Temporary accommodation costs when you have contents cover

We cover	<p>When you have contents cover and damage to your contents by an insured incident is the sole reason you cannot live at your home or unit, we will pay for your temporary accommodation costs for the time it takes to repair or replace your contents to a liveable condition.</p> <p>We will pay:</p> <ul style="list-style-type: none">➤ up to 2 weeks in short term accommodation agreed to by us (e.g. standard rates for a hotel, motel or serviced apartment), then if necessary:➤ up to another 50 weeks in residential accommodation of a similar standard to your home or unit. The amount we will pay is based on the weekly rent you would receive for your home or unit at the time of the claim. We will ask a licenced local property manager to assess this amount. <p>If you don't have to pay rent during the repair period, we will deduct the amount you would pay for rent from what we pay you.</p> <p>The limit for temporary accommodation is 10% of your contents sum insured and the longest period you can claim for is 52 weeks. We will pay this in addition to the sum insured for your contents.</p>
We do not cover	<p>Temporary accommodation costs:</p> <ul style="list-style-type: none">➤ if damage to the home or building is the reason why you cannot live there➤ if you do not need to pay for temporary accommodation beyond the period it should reasonably take to replace or repair your contents so you can live in your home or unit again➤ if you were not living at the home or unit at the time of the loss or damage➤ if you did not intend to live at your home or unit during the repair period had your contents not been damaged.

1c. Temporary accommodation costs when you cannot access your home or unit

We cover	<p>This additional feature provides cover when you have:</p> <ul style="list-style-type: none">› home cover or› contents cover in a unit or› contents cover in a home that you are renting. <p>If you cannot access your home or unit because one of the following incidents happens within 500 metres from the insured address:</p> <ul style="list-style-type: none">› damage to a building, road or street› burst water main› bomb threat or bomb damage› street riot› emergency services refuse you access <p>then we will pay the cost of temporarily accommodating you in a home of a similar standard to the insured address. The amount we pay will be based on the market's weekly rental value of your home, unit or rented home.</p> <p>We will pay for accommodation up to the time you can access your home, unit or rented home again, but we will not pay for more than 12 weeks accommodation. We will pay this in addition to the sum insured for your contents.</p>
We do not cover	<p>Temporary accommodation costs:</p> <ul style="list-style-type: none">› caused by incidents happening more than 500 metres from the insured address› if you were not living in your home or unit at the time of the loss or damage› if your temporary accommodation is free› caused by the threat of, or damage by, a nuclear or biological bomb› when you own and live in your home and do not insure your home under this policy.

2a. Removal of debris

We cover	<p>Removal of debris and making the home safe</p> <p>When your home is damaged by an insured incident, we will pay the reasonable and necessary costs to:</p> <ul style="list-style-type: none">› remove the damaged parts of your home from the insured address› demolish the home if necessary, and› make the home safe if it can't be lived in. <p>If we authorise the repair or rebuilding of your home, we will also pay the reasonable and necessary cost of:</p> <ul style="list-style-type: none">› temporary fencing› fees from quantity surveyors, land surveyors, architects and engineers› building application fees and legal work to repair or rebuild.› The limit for this additional feature for any one insured incident is 20% of the home sum insured. We will pay this in addition to the sum insured for the home. <p>Removal of debris and keeping contents safe</p> <p>When your contents are damaged by an insured incident, we will pay the reasonable and necessary costs to:</p> <ul style="list-style-type: none">› dispose of damaged contents and› store undamaged contents during the reasonable time it should take to repair the home. <p>The limit for this additional feature for any one insured incident is 20% of your contents sum insured. We will pay this in addition to the sum insured for your contents.</p>
We do not cover	<p>The following costs if you had planned to demolish your home before the insured incident:</p> <ul style="list-style-type: none">› costs to remove debris› extra rebuilding costs› costs to demolish your home or make your home safe.

More details

For further details about how we pay claims under additional feature 2a. Removal of debris, please refer to our Premiums, Excesses, Discounts and Claim Payments Guide available at gio.com.au/moredetails. A copy of this guide can be provided to you on request, at no charge, if you contact us on 13 10 10.

2b. Safety net home protection

We cover	<p>When your home is damaged by an insured incident and the cost of repairing or replacing it exceeds the sum insured, then we will pay up to a further 30% of your home sum insured to:</p> <ul style="list-style-type: none">➤ repair damage or➤ replace your home or➤ pay you what it would cost us to repair or replace your home.
Note	<p>The cover in safety net home protection does not increase your home sum insured. Any additional feature based on a percentage of the home sum insured does not increase.</p> <p>For example, the most we will pay for removal of debris for a home claim is 20% of your home sum insured. The sum insured for this feature is not increased as a result of having safety net home protection.</p> <p>Safety net home protection is designed to give you some extra protection against being affected by under-insurance outside your control.</p> <p>You are responsible for insuring your home for what it costs to completely rebuild it using new materials. Even though you may do this, your sum insured can still fall short if building costs suddenly surge above normal after a disaster.</p> <p>Our experience is that building costs can surge after widespread natural disasters like storms, cyclones and bushfires, causing greater demands on builders and materials.</p>
Contact us immediately if you increase the size of your home	<p>After you take out this policy, if you ever increase the size of your home (e.g. extending a room or adding a garage) you need to tell us and review your home sum insured. This is important because the cost to rebuild your home may have increased.</p> <p>If the increase to the size of your home is more than 10% and you do not contact us to appropriately adjust your sum insured, the most we will pay under this feature reduces from 30% to 15% of your sum insured.</p>

More details

For further details about how we pay claims under additional feature 2b. Safety net home protection, please refer to our Premiums, Excesses, Discounts & Claim Payments Guide available at gio.com.au/moredetails. A copy of this guide can be provided to you on request, at no charge, if you contact us on 13 10 10.

3a. Extra costs to comply with the latest home building regulations

We cover	<p>When rebuilding or repairing damaged parts of the home, we will pay for the extra cost of making these parts comply with the latest home building regulations and laws.</p> <p>The extent of upgrade needed will depend on how old your home is and what building regulations have changed since your home was built. The cover in this feature is not paid in addition to your home sum insured, so always keep your sum insured up to date with the latest new rebuilding cost.</p>
We do not cover	<ul style="list-style-type: none">➤ cost to upgrade undamaged parts of your home to comply with the latest building regulations➤ costs to make the home comply with building regulations that existed when the home was originally built or altered.

3b. Rainwater tank or solar heating system

We cover	<p>When your home is insured under this policy, we will pay up to \$2,500 of your net costs* to install a rainwater tank, solar heating system or both at your home.</p> <p>This benefit is payable when:</p> <ul style="list-style-type: none">➤ 80% or more of your home is damaged by an insured incident and➤ your home does not have a rainwater tank or solar heating system and➤ your sum insured (plus cover under safety net home protection, refer to additional feature 2b) adequate to repair or rebuild your home and➤ we have authorised or arranged the repairs or rebuilding of your home. <p>*Net cost is the amount you spend after deducting any government subsidy you are entitled to. You must supply us with proof of the amount you spent before we will pay you.</p> <p>Rainwater tank includes:</p> <ul style="list-style-type: none">➤ a rainwater tank or bladder➤ an electric pump and wiring➤ a tank stand and base➤ pipes connecting roof drainage to the tank, pump and parts of your home➤ installation costs. <p>Solar heating system includes:</p> <ul style="list-style-type: none">➤ collector panels and tubes that catch and store the sun's energy➤ a water tank electric pump and wiring➤ a tank stand and base➤ pipes connecting the collector panels or solar tubes from roof, to tank, pump and parts of your home➤ installation costs.
We do not cover	<ul style="list-style-type: none">➤ any costs unless you have entered into a contract for the supply of the rainwater tank or solar heating system within 30 days of settling your claim➤ any amount covered under additional feature 3a. extra costs to comply with the latest home building regulations.

4. Motor burnout

We cover	<p>The burning out or fusing of a household electric motor which is part of the insured home or contents.</p> <p>Cover includes repairing or replacing:</p> <ul style="list-style-type: none">› the electric motor or compressor containing the motor› an entire sealed unit, filter, dryer and regassing if the electric motor is inside a sealed refrigeration or air conditioning unit› a swimming pool water pump combined with its electric motor, if the replacement pump motor cannot be bought on its own.
We do not cover	<ul style="list-style-type: none">› any motor or sealed unit aged 11 years or more› the cost of extracting or re-installing a submersible pump› any amount you can recover under a manufacturer's guarantee or warranty.› Motors in any:<ul style="list-style-type: none">› television, video recorder, DVD player or recorder› computer, printer or computer equipment› microwave oven› radio, stereo, hi-fi or other sound equipment› appliance or fixture that is used for a business activity. <p>Motor burnout – when the motor cannot be replaced</p> <p>If an electric motor or motor in an appliance cannot be replaced, we will pay the replacement cost of an equivalent motor or motor in a sealed unit of the same specification and standard available today. We will not pay for replacement of the whole appliance.</p>

More details

For further details about how we pay claims under additional feature 4. Motor burnout, please refer to our Premiums, Excesses, Discounts and Claim Payments Guide available at gio.com.au/moredetails. A copy of this guide can be provided to you on request, at no charge, if you contact us on 13 10 10.

5. Spoilage of food

We cover	<p>When your contents are insured, we will cover spoilage of frozen or refrigerated food or medicines caused by:</p> <ul style="list-style-type: none">› the burning out or fusing of a household electric motor which is part of the insured home or contents› the power to your freezer or refrigerator being accidentally switched off or failing due to an electricity safety device cutting out› any other incident insured by this policy. <p>The limit we will pay is \$2,000 for any incident resulting in a claim.</p>
We do not cover	<p>Food or medicine spoilage resulting from:</p> <ul style="list-style-type: none">› the burning out of any motor or sealed unit aged 11 years or more› a deliberate act or shut-down by you or your power provider› the failure of your power provider to meet demand in power supply› the failure of or breakdown of any part of the refrigerator or freezer other than the motor or motor in a sealed unit (e.g. leaking gas).

6. Removal of trees that have fallen and damaged your home

We cover	<p>When your home is damaged by a falling tree, in addition to repairing your home we will cover the cost of removing fallen trees from your home to enable repair and dispose of them at the nearest waste disposal facility.</p> <p>When your contents are insured we will also cover the cost of removing the fallen tree, if it has:</p> <ul style="list-style-type: none">› damaged your contents in the open air and› not damaged your home.
We do not cover	<p>The cost of removing or disposing of:</p> <ul style="list-style-type: none">› tree stumps or roots that are still in the ground› fallen trees or branches that have not damaged the home unless they have damaged your contents in the open air› potentially dangerous trees which have not damaged your home.

7. Exploration costs to find the source of leaks from pipes and drains

We cover	<p>When we insure your home we will cover the reasonable cost of searching for the unknown cause of leaks in pipes in your home but only if the leaking liquid is causing permanent damage to your home or contents.</p> <p>After we find the cause of a leak, we will:</p> <ul style="list-style-type: none">› pay up to \$500 plumbing costs to repair or replace a leaking pipe› repair and restore damage caused by our exploratory work› if necessary, pay extra to match or complement undamaged materials to new materials in the same room, hallway, stairs or passageway where the damage occurred. <p>We will pay:</p> <ul style="list-style-type: none">› up to \$1,000 for wall tiles› the full cost of replacing floor and other wall coverings.
We do not cover	<ul style="list-style-type: none">› damage to retaining walls› fixing or finding leaks that have not caused permanent damage to your home or contents (e.g. a pipe leaking water over an outdoor pathway)› searching for leaks in a shower floor or base, shower cubicle walls, shower glass screening or shower doors, or fixing them or upgrading them so they do not leak unless the damage is caused by water leaking from pipes in walls or floors (not forming part of a shower floor or base)› fixing broken, worn or aged tiles or grouting in walls in showers, bathrooms, kitchens or laundries unless the damage is caused by liquid leaking from pipes in walls or floors (not forming part of a shower floor or base).

8. Replacement of locks

We cover	<p>When you have home or contents cover, we will pay the necessary cost of replacing locks to the external doors or windows of your home or unit or changing their key codes if keys to those locks are stolen anywhere in Australia or New Zealand.</p> <p>The limit is \$2,500 for any incident resulting in a claim.</p>
-----------------	--

9. Fees charged by the security services provider for your monitored alarm

We cover	If your home or unit is illegally broken into by an intruder and your monitored alarm is activated, we will pay the fee charged by your security provider to respond. The limit is \$2,500 for any incident resulting in a claim.
We do not cover	Fees charged: <ul style="list-style-type: none">➤ when your home or unit has not been broken into➤ following a false alarm (e.g. a cat or dog has triggered the alarm).

10. Credit or financial transactions card cover when your contents are insured

We cover	If your credit or financial transaction card is lost or stolen from your home or unit, then we will pay for loss or theft of your money because your card has been used fraudulently. The limit for this feature is \$5,000 for any incident resulting in a claim. Any amount we agree to pay will be reduced by the amount your financial institution or credit provider reimburses or agrees to reimburse you for the theft.
We do not cover	<ul style="list-style-type: none">➤ loss or theft occurring because you did not follow the terms and conditions of use for your card and:<ul style="list-style-type: none">➤ someone used your card after they found or had access to your PIN or➤ you did not tell the financial institution or credit provider who issued your card within 24 hours after you discover the card is lost or stolen➤ theft by you or anyone who lives with you in your home.

11. Identity theft cover

We cover	<p>When you have contents cover and you are a victim of identity theft, then we will pay the costs you have to pay in trying to re-establish your personal credit history, including:</p> <ul style="list-style-type: none">› your unpaid wages for any time you had to take off work because of this› extra loan application fees that you incur from having to re-apply for a loan declined because of false credit history as the result of identity theft› costs to obtain and correct your credit rating report› telephone, fax and postage costs spent on recreating your credit worthiness› travel costs including fares for trains, trams, buses, aircraft and taxis spent on recreating your credit worthiness› legal fees we have agreed in writing to pay (before you incurred them) to:<ul style="list-style-type: none">› defend actions brought against you incorrectly by retailers and collection agencies following the theft of your identity› remove wrongly recorded civil judgements against you› challenge the accuracy of any Australian credit reporting agency or bureau› prepare legal statements, statutory declaration or affidavits required by the police, your bank or credit provider. <p>The most we will pay under this additional feature for all claims made in the period of insurance is \$2,000.</p>
We do not cover	<ul style="list-style-type: none">› payment of any debts resulting from identity theft› any costs or fees incurred in reinstating your credit status or good name relating to or for a business activity› speeding or parking fines or infringements› costs to re-establish identity or credit records outside Australia› any costs recoverable from your bank, credit card or credit provider› identity theft which happened because you did not follow the terms and conditions of any bank, credit provider or other financial institution for keeping your identification or access details safe (e.g. keeping your PIN details with the card)› costs not supported by written evidence showing us:<ul style="list-style-type: none">› when they were incurred› that they clearly resulted from a claim under this additional feature› legal fees or costs:<ul style="list-style-type: none">› for actions in courts outside Australia and› not approved by us in writing before you incurred them.

12a. Moving to a new home address in Australia

We cover	<p>When you have contents cover and you are moving to a new address in Australia we will cover your contents while they are being moved for loss or damage caused by:</p> <ul style="list-style-type: none">➤ fire➤ flood➤ collision or overturning of the vehicle carrying them. <p>(Note – if you want extra cover, you can apply for separate goods in transit insurance. Ask us for more information)</p>
We do not cover	<ul style="list-style-type: none">➤ loss or damage caused by an incident not shown as insured.

12b. Contents at your old and new address

We cover	<p>When you have contents cover we will cover your contents at your new address and old insured address for up to 14 days from the date you begin to move.</p>
We do not cover	<p>Contents at your new address after 14 days from the day you begin to move, unless you tell us to change your insured address and we agree to cover your contents there.</p>

13. Extra costs to re-establish important documents

We cover	<p>When you have contents cover we will pay the costs to replace these documents if they are damaged by an insured incident:</p> <ul style="list-style-type: none">› valuations for your home and contents items› passports› wills› the land title to your home› driver licences› marriage certificates› birth certificates› Australian citizenship certificates› tertiary education certificates. <p>The limit for any incident resulting in a claim is \$2,000.</p>
We do not cover	Any document not shown as insured.

14. Plants, shrubs and trees in gardens

We cover	<p>When you have home cover or contents cover in a unit we will also insure your plants, shrubs and trees at the insured address for loss or damage caused by:</p> <ul style="list-style-type: none">➤ fire➤ vandals and people rioting➤ thieves and➤ impact by a vehicle or aircraft. <p>We will pay the cost of replacing the plant, shrub or tree with one that we consider is reasonably similar to the one lost or damaged.</p> <p>The limit for any incident resulting in a claim is \$1,500.</p>
We do not cover	<ul style="list-style-type: none">➤ lawns and grass➤ loss or damage caused by herbicide or poison.

15. Uninsured contents owned by visitors or employees

We cover	<p>When you have contents cover, we will cover loss or damage by an insured incident at the insured address to:</p> <ul style="list-style-type: none">➤ uninsured contents of your visitors when the visitors are staying overnight at your home or unit➤ uninsured contents owned by your domestic employees. <p>The limit for any incident resulting in a claim is \$2,000.</p>
We do not cover	<ul style="list-style-type: none">➤ incidents happening away from the insured address➤ any item insured under another policy➤ jewellery➤ cash or documents able to be cashed➤ mobile phones or devices with mobile phone functionality.

16. Accessories and spare parts of vehicles and craft

We cover	<p>When you have contents cover we will cover the spare parts and accessories for the following vehicles and craft at the insured address:</p> <ul style="list-style-type: none">› motor vehicles or trailers, motor cycles, mini-motor cycles› motorised scooters or motorised bicycles› watercraft (but not outboard motors)› aircraft. <p>The insured incidents we cover under this feature are:</p> <ul style="list-style-type: none">› fire› theft. <p>The limit is \$2,000 for any incident resulting in a claim.</p>
We do not cover	<ul style="list-style-type: none">› keys for these vehicles or craft or replacement of their locks› outboard motors› spare parts or accessories that are in or on the vehicle or craft at the time of the fire or theft.

17. Funeral expenses

We cover	<p>When you have home cover or contents cover we will pay the cost of your funeral expenses if:</p> <ul style="list-style-type: none">› you die as a direct result of an insured incident and› we have paid a claim for loss or damage to your home or contents resulting from that incident. <p>The limit for this feature in any one period of insurance is \$5,000.</p>
We do not cover	<p>Funeral expenses:</p> <ul style="list-style-type: none">› if your death is from an incident that happens away from the insured address› your death occurs more than 90 days after the event that caused it.

18. Home modifications due to paraplegia or quadriplegia

We cover	<p>When you have home cover or contents cover in a unit that you own, we will pay the necessary cost of modifying your home to help your mobility if:</p> <ul style="list-style-type: none">➤ you are injured as a direct result of an insured incident and➤ this injury results in permanent paraplegia or quadriplegia and➤ we have paid a claim for loss or damage to your home or contents resulting from this incident. <p>The limit for this feature in any one period of insurance is \$10,000.</p>
We do not cover	<p>Home modifications if the paraplegia or quadriplegia occurs more than 90 days after the insured event that caused it.</p>

19. Mortgage discharge costs

We cover	<p>When you have home cover and we pay a claim for your home to a credit provider that fully repays the home loan, then we will pay the administrative and legal costs of:</p> <ul style="list-style-type: none">➤ discharging the mortgage and➤ deleting the mortgagee from the land title on your home. <p>The limit for this feature in any one period of insurance is \$2,000.</p>
We do not cover	<p>Penalty interest rate charges or early loan repayment charges imposed on you by the credit provider.</p>

20. Legal liability cover

The most we will pay for all claims from any one incident under home and contents legal liability cover is **\$20 million** including all associated legal costs we have agreed to pay following your claim.

For what is not covered under this additional feature see 'We do not cover loss or damage or liability:' on page 47 and 'We do not cover legal liability caused by or resulting from:' on pages 48 to 50.

20a. Legal liability when you have home cover

When you have home cover under this policy	We cover your legal liability to pay compensation for death or bodily injury to other people or loss or damage to their property resulting from an incident which happens: <ul style="list-style-type: none">➤ in connection with you owning or living in the home and➤ at the insured address.
---	---

20b. Legal liability when you have contents cover

When you have contents cover under this policy	We cover your legal liability to pay compensation for an incident causing death or bodily injury to other people, or loss or damage to their property which happens anywhere in Australia or New Zealand.
Additional cover for a vacant block of residential land	When you have contents cover we cover your legal liability resulting from an incident which happens on a vacant block of land that: <ul style="list-style-type: none">➤ you own and➤ is zoned for residential housing and➤ is no more than 20 acres or 8 hectares and➤ is where you intend to build your future home. The longest we will provide this cover is for 24 months from the time you became the owner of the land. It stops when you insure a home on the land or sell the land.
Additional cover for a block of land where your home was destroyed	When you have home and contents cover and your home is destroyed in an insured incident, and you continue to insure your contents cover with us, we cover your legal liability legal liability resulting from an incident which happens on a residential block of land where: <ul style="list-style-type: none">➤ your home policy stopped because we paid a total loss claim and➤ you intend to rebuild your home on this land. The longest we will provide this cover is for 24 months from the time your home was destroyed by an insured incident. It stops if you insure a new home on the land or sell the land.

21. Automatic adjustments to the sum insured

We cover	<p>When your home policy is due for renewal</p> <p>At each renewal, we will review and adjust your sum insured, taking into account trends in industry building costs and the cost of rebuilding your home. This may help reduce the risk of any potential under-insurance of your home.</p> <p>We will use data such as past experience, industry home building cost guides, home building values, average sums insured for your immediate area, our claims information and any record we have of previous sum insured values for your insured address.</p> <p>When your contents policy is due for renewal</p> <p>At each renewal, we will review and adjust your sum insured taking into account additional items you might buy during the period of insurance and increases in the replacement cost of contents. This may help reduce the risk of any potential under-insurance of your contents.</p> <p>We will use data such as past experience, industry cost guides, our claims information and the average sum insured for your immediate area.</p>
Note	<p>Review the adjusted sum insured</p> <p>When you receive your renewal offer, your certificate of insurance will show the adjusted sum insured. If you do not wish to accept the adjusted sum insured, you can ask us to change it. We will tell you if we have any minimum sum insured requirements and if we agree to your requested sum insured.</p> <p>We will not automatically adjust the sum insured on:</p> <ul style="list-style-type: none">➤ any listed contents item (you need to revalue these items regularly to make sure they are insured for the new for old replacement cost)➤ mortgagee's interest option under optional cover 2. <p>We also bring forward the adjustment if your sum insured is inadequate at the time of a claim. More information on how an early adjustment is calculated on page 60.</p>

More details

For further details about how we bring forward the adjustment to the sum insured at a time of a claim, please refer to our Premiums, Excesses, Discounts and Claim Payments Guide available at gio.com.au/moredetails. A copy of this guide can be provided to you on request, at no charge, if you contact us on 13 10 10.

Optional covers

You can ask us to add one or more of the following optional covers to your policy for an extra premium. Sometimes an option might not be available and we will tell you if this is the case.

Optional covers may have their own excess amounts which will be shown on your certificate of insurance.

If you choose and pay for an option:

- that option will be shown as covered on your certificate of insurance **and**
- you will be covered for loss, damage or injury under that option caused by an accident or incident in the period of insurance.

1. Injury to pet dogs and cats

We cover	<p>If a pet dog or cat shown on your certificate of insurance is injured in an accident during the period of insurance, then we will pay for necessary veterinary treatment.</p> <p>The most we will pay for all treatment (initial and ongoing) resulting from any one accident is \$2,000.</p>
We do not cover	<p>Treatment for:</p> <ul style="list-style-type: none">➤ any illness➤ harm caused by something the animal has eaten or any other digestive system ailment➤ coronary failure or coronary thrombosis (e.g. a heart attack)➤ veterinary expenses incurred after your pet dies (e.g. autopsy or disposal costs)➤ routine, elective or preventative veterinary treatment such as vaccinations, de-sexing or heart worm testing➤ any condition or injury that existed before you took out this cover (pre-existing conditions)➤ insect bites or infestation by insects such as heart worm, fleas or mites, but we will cover tick bite and tick poisoning➤ injury from doing a business activity such as security, racing, farming and grazing, but we will cover dogs and cats kept or used for breeding or showing.

2. Mortgagee’s interest for unit owners with a mortgage

<p>We cover</p>	<p>If the unit shown on your certificate of insurance suffers loss or damage by an insured incident:</p> <ul style="list-style-type: none"> ➤ and the body corporate building insurance either doesn’t apply or fully cover the cost of repairing the building ➤ and the mortgagee on your unit makes a claim under your policy for repayment of the mortgage ➤ then we will pay the mortgagee the lower of these 2 amounts: <ul style="list-style-type: none"> ➤ the amount to fully repay your mortgage at the time of the loss or ➤ the sum insured for the mortgagee’s interest shown on your certificate of insurance.
<p>Note</p>	<p>This optional cover is only available if you insure contents in a unit under this policy.</p>
<p>We do not cover</p>	<ul style="list-style-type: none"> ➤ additional features 1 to 21 ➤ any incident not insured by this policy.

3. Domestic workers compensation

<p>We cover</p>	<p>Your legal liability to pay workers compensation to your domestic employee:</p> <ul style="list-style-type: none"> ➤ if your employee is injured while working for you and ➤ the incident causing the injury occurred in the period of insurance. <p>The terms and extent of cover are those set out in the relevant workers compensation laws of the state or territory of the insured address.</p> <p>This option is only available in Australian Capital Territory and Western Australia. If you live in other states or territories and employ a domestic employee, you may need to arrange this cover with the WorkCover Authority or other insurance providers.</p>
<p>We do not cover</p>	<ul style="list-style-type: none"> ➤ workers compensation for your employees if you are a company ➤ or if they are engaged in: <ul style="list-style-type: none"> ➤ any business activity ➤ building or renovating your home, other than routine maintenance at the insured address ➤ work in and around your home if your home is rented out to tenants (you are a landlord). <p>If you employ someone for these activities, please contact us to see if we can provide a separate workers compensation policy or you can contact your state workers compensation authority to see what your options are.</p> <p>The workers compensation laws in the state or territory of the insured home or contents will state what is not insured.</p>

What you are not covered for

This section details what is not covered under any part of your policy.

We do not cover:

Failing to take care of the home or contents

Loss or damage caused by, or as a result of, your failure to:

- › take reasonable care of your home and contents
- › keep the home and contents in good condition and well maintained
- › fix faults and defects as soon as you become aware of them.

Defect, structural fault or faulty design

Loss or damage caused by a defect, structural fault or design fault that you knew about (or should reasonably have known about) and did not fix before the loss or damage occurred (e.g. if there are signs that a defect previously caused damage, we will not pay a later claim for further damage from this defect).

Tanks that explode

The cost of repairing or replacing tanks or containers that explode, **but we will cover** damage to the home and contents caused by the explosion.

Water containers that burst or leak

The cost of repairing or replacing water containers that burst or leak such as a hot water tank bursting or leaking, **but we will cover**:

- › water or liquid damage to the home and contents caused by bursting or leaking water containers
- › bursting or breaking of glass in fish tanks but not fish bowls.

Leaking pipes not causing permanent damage

The cost of locating and fixing leaking or overflowing pipes, drains or water containers that have not, or are not causing permanent damage to your home or contents.

Leaks in shower bases, shower floors or their walls

The repair of a leaking shower floor or base, shower cubical walls, shower glass screening or shower doors, or any damage caused by the leak.

We do not cover:

Erosion, subsidence

Loss or damage caused by or as a result of erosion, vibration, subsidence, landslip, landslide, mudslide, collapse, shrinkage or any other earth movement, **but we will cover** subsidence damage to your home if it is caused by:

- liquid bursting, leaking or overflowing of water or liquids from water containers
- any of these insured incidents if the damage they cause happens within **72** hours of the insured incident:
 - storm and flood
 - explosion (except from any nuclear or radioactive cause)
 - earthquake or tsunami.

Mould, rising damp, rust, corrosion

Loss or damage caused by mould, rising damp, mildew, action of light, atmospheric or climatic conditions, corrosion or rot **unless it is caused by** bursting, leaking or overflowing of water or liquid at the insured address from water containers (e.g. a pipe bursting).

Seepage of water through the earth

Loss or damage caused by water seeping or running:

- through the earth (sometimes called hydrostatic water seepage)
- through or down the sides of earth or earth fill that is up against your home
- down the sides or underneath swimming pools or spas causing them to move, change shape or lift or leaking through their hydrostatic valves
- against or through retaining walls and forcing them to move or crack

but we will cover damage caused by water or liquid leaking or overflowing from water containers (e.g. a pipe bursting) but we will not cover damage to retaining walls.

Actions or movements of the sea

Loss or damage caused by actions or movements of the sea, **but we will cover:**

- damage caused by tsunami
 - damage caused by storm surge if it occurs at the same time your home or contents are damaged by a storm or flood.
-

We do not cover:

Not covered for storm or flood

The following, if caused by storm or flood:

- › the cost of cleaning mud or debris out of tanks, swimming pools or spas
- › damage to swimming pools and their parts or underground tanks caused by water leaking down the sides, against their sides, or getting underneath them
- › storm or flood damage to:
 - › retaining walls, garden borders or free standing walls
 - › the surface of a tennis court
 - › a wharf, jetty, pontoon or sea wall
 - › water in a tank, swimming pool or spa
 - › liners or covers for swimming pools or spas
 - › paint when there is no structural storm damage to other parts of the home
 - › gates, fences or wall fences that were in a state of disrepair which would have been obvious to a reasonable person before the damage occurred.

Power surge or shut down by your power provider

Loss or damage caused by power surge or shut down by your power provider, **but we will cover:**

- › fire damage resulting from power surge
- › damage to electric motors covered under additional feature 4. motor burnout
- › damage from a power surge caused by lightning but only when:
 - › the Australian Government Bureau of Meteorology has a record of lightning in your area at the time of the damage **and**
 - › you show us written confirmation from a qualified repairer that lightning was the cause.

Mechanical or electrical breakdown or computer virus or computer hacker

The cost of repairing or replacing any item made necessary because of mechanical or electrical failure or breakdown, anything that fails to operate properly, or loss or damage caused by a computer virus or computer hacker, **but we will cover:**

- › damage to electric motors under additional feature 4. motor burnout
- › fire spreading from an electrical fault to other parts of your home and contents
- › damage caused by lightning when:
 - › the Australian Government Bureau of Meteorology has a record of lightning in your area at the time of the damage **and**
 - › you show us written confirmation from a qualified repairer that lightning was the actual cause.

Tree, plant and shrub roots

Damage caused by the roots of trees, shrubs or plants, **but we will cover** damage caused by liquid leaking or overflowing from pipes or drains that are blocked or damaged by these roots.

We do not cover:

Wear, tear and gradual deterioration

The cost of fixing or repairing wear, tear, rust, fading or gradual deterioration such as (but not limited to):

- › tiles and their adhesive or grouting breaking down
- › weathering of roof tiles or roof ridge capping
- › gradual weathering and breakdown of bricks, mortar or concrete
- › leaking or bursting pipes or water containers such as tanks bursting or leaking, **but we will cover** damage to the home and contents caused by water or liquid leaking from water containers, pipes and drains.

Loss or damage by tenants, paying guests or boarders

Loss or damage caused by tenants, paying guests or boarders, or someone who lives with them or a person who entered the home or unit with their consent, **but we will cover these incidents if caused by them:**

- › fire damage
- › explosion
- › impact by a vehicle
- › breakage of fixed glass and water containers
- › water or liquid leaking or overflowing from pipes or water containers.

Theft or malicious damage by someone you invited into the home

Theft or malicious damage by:

- › you or someone who lives in the home or unit **or**
- › someone who entered the home or unit with:
 - › your consent **or**
 - › the consent of someone with your authority to access your home.

When security or alarms are not working

Loss by theft if the door locks, window locks or alarms you told us were installed, were in fact not installed, not in working condition, disconnected, or not used as intended and we relied on them being there as a reason for accepting and continuing your policy (however, forgetting to turn on your alarm or to lock a door will not affect theft cover under your policy).

Anything you don't own

Loss or damage to any home, contents or property you don't own, **but we will cover:**

- › uninsured contents owned by visitors (covered by additional feature 15)
 - › contents you borrowed and are legally liable for under a written contract other than a tenancy rental agreement
 - › your legal liability for loss or damage to the property of others under legal liability (covered by additional feature 20).
-

We do not cover:

Business activity

Loss or damage to any part of your home used for any business activity or loss or damage to contents kept in this area **except when the business activity is:**

- › letting up to **2** bedrooms to paying guests or boarders (e.g. bed-and-breakfast accommodation)
- › using part of your home as a home office
- › one you told us about and we agreed to continue cover and this is noted on your certificate of insurance.

Chemical damage when cleaning

Damage caused by chemicals, such as detergents and solvents, when you or someone authorised by you is using them for cleaning.

Food spoilage

Spoilage of food and medicines other than the cover provided under additional feature 5.

Scorching, smoke, ash or soot when your home has not caught on fire

- › damage from scorching, heat, smoke, ash or soot when your home or contents have not caught on fire, **but we will pay for** damage which is caused by a burning building within **10** metres of your home
- › damage by smoke, pollution or vapour from a home heater or a cooking appliance, **but we will pay for** fire damage to your home or contents (including the heater or cooking appliance) if a fire gets out of control, escapes and damages other parts of your home and contents
- › damage caused by cigarette or cigar marks or burns, **but we will pay for** damage caused by a fire which spreads from the initial burn spot.

Sporting equipment or remote-controlled models when in use

Loss or damage to sporting equipment or remote-controlled models when actively in use, such as:

- › breaking a tennis racquet or golf club when trying to hit a ball
- › losing or breaking a fishing rod when reeling in a fish or while being used to lure or trawl for fish
- › breaking a surfboard in surf
- › tearing a windsurfer's sail while windsurfing
- › impact damage while using a remote-control model or toy aircraft, motor vehicle or watercraft, **but we will pay for** damage to a bicycle while being ridden but not damage to the tyre of the bicycle.

We do not cover:

Animals biting, chewing, pecking or clawing

Loss or damage caused by animals biting, pecking or clawing the home or contents or damage caused by their excrement or urine (e.g. birds chewing and biting parts of your home made of wood or cats clawing furniture), **but we will pay for** damage to your contents caused by an animal which does not belong to you or anyone living in your home while it is accidentally trapped inside your home.

Insects, birds and vermin

Loss or damage caused by insects, birds or vermin (e.g. termites, rats, rabbits and mice), **but we will cover:**

- › fire damage they cause
 - › water damage they cause.
-

You lopping trees

Damage caused by you or a person authorised by you, lopping, felling or transplanting trees.

Photographs, electronic data and images

- › The cost of repairing, replacing or fixing electronic data or files that are corrupted, damaged or lost, **but we will cover them** if the device they are stored on is lost or damaged by an insured incident and:
 - › you can show us proof of purchase **and**
 - › you cannot restore them through your supplier free of charge
 - › photographs, films or visual images stored electronically or on any other medium, including hardcopies that are corrupted, damaged or lost, **but we will cover** photographs purchased as a work of art or furnishing from a retail outlet.
-

Other circumstances which we do not cover:

Aircraft shock waves

We do not cover damage caused by the gradual affects of vibrations, or shock waves caused by aircraft travelling at high speeds unless you can clearly show us that the damage was caused by a single destructive incident (e.g. sonic boom).

Building extensions, alterations or renovations

When you make building alterations, extensions or renovations to your home or unit, we do not cover:

- › damage caused by cracking, collapse, subsidence or damage to your home or contents caused fully or partly by the new building work
- › damage caused by water entering your home through openings in the walls or roof or other unfinished parts of your home whether or not they are covered by tarpaulins at the time of the damage
- › damage caused by storm or flood to any part that is not fully built
- › malicious damage or vandalism to unfinished parts of the new work or contents in these areas
- › theft by someone who enters or leaves through an unfinished part of your home (even if that part of the home was temporarily secured or covered) **or**
- › legal liability for incidents under additional feature 20 as a result of building, altering or renovating your home **unless** your home is insured by your policy and the total cost of building, altering or renovating is no more than **\$100,000**.

Home unoccupied for longer than 100 days

We do not cover loss or damage that occurs after your home has been unoccupied for longer than **100** consecutive days unless you have told us about this and we have agreed to provide cover in writing. See page 69 for more details.

Not complying with building laws

If your home does not comply with building laws or regulations except those laws or regulations introduced after your home was originally built or altered which you are not legally required to comply with.

The first 72 hours of cover for bushfires, storm or floods

We do not cover damage caused by a bushfire, storm or flood occurring within the first **72** hours from the start of this insurance cover, **but we will cover these incidents if this policy began on the same day:**

- › you bought your home
- › another policy covering your home or contents expired. If this is the case, we pay up to the sums insured covered under the expired policy (any increase in sums insured will not be covered for these incidents in the first **72** hours).

Other circumstances which we do not cover:

Extra costs following an insured incident

Consequential losses or extra costs following an insured incident including:

- the cost of replacing or re-applying pest control chemicals and baits in or around your home
- loss of water from a bursting or leaking pipe or water container
- loss of income or wages
- the cost of your time to prove your loss or to help us assess your claim
- the cost of hiring appliances after yours are lost, damaged or stolen **or**
- professional, expert, legal, consulting or valuation costs unless you obtained our prior written authority to incur these costs

but we will cover:

- removal of debris and extra rebuilding costs (covered by additional feature 2a.)
- temporary accommodation (covered by additional feature 1)
- motor burnout (covered by additional feature 4).

Breaking the law

We do not cover any loss or damage:

- arising when you or someone with your knowledge or permission uses any part of the home for criminal or unlawful purposes
 - you caused or contributed to because you possessed, supplied or consumed illegal substances or illegal drugs.
-

We do not cover loss or damage or liability:

Confiscation or damage by a legal authority

Caused by confiscation, nationalisation, requisition or damage caused by the police, a government authority or someone with the legal authority to do this.

Deliberate actions by you

Caused by an act or omission by you, your family or any owner or part owner of your home or contents, or anyone acting with your consent which:

- is deliberate
 - demonstrates a reckless disregard for the consequences of that action or omission.
-

Revolution, war

Caused by revolution, war (whether war is declared or not) or other acts of foreign enemy, military coup or any looting or rioting following these incidents.

Biological, chemical, other pollutant or contaminant

Caused by any biological, bacterial, viral, germ, chemical or poisonous pollutant or contaminant or any looting or rioting following these incidents, **but we will cover:**

- damage caused by smoke when we have paid a claim for fire damage to your home or contents
 - your legal liability (covered under additional feature 20) caused by your use of pesticides or herbicides at the insured address.
-

Radioactivity

Caused by radioactivity or the use, existence or escape of nuclear fuel, nuclear material or waste, or action of nuclear fission including detonation of any nuclear device or nuclear weapon or any looting or rioting following these incidents.

Flood caused by deliberate damage to a reservoir or dam

Flood damage caused by deliberate or malicious damage to, or destruction of a reservoir or dam, or any looting or rioting following these incidents.

We do not cover legal liability caused by or resulting from:

Agreements you enter into

Any agreement or contract you enter into, but we will cover your legal liability:

- › to the extent that it would have existed had you not entered into the agreement or contract
- › if you have contents cover and your liability is:
 - › under a tenancy rental agreement **and**
 - › for damage to your landlord's property at the insured address caused by fire or by water leaking from pipes, washing machines, dishwashers or water overflowing from a blocked bath or tub.

Aircraft

Using or owning any aircraft unless it is a:

- › remote-controlled model aircraft with a wingspan up to **1.5** metres
- › kite designed to be held by a person on land or attached to a watercraft (e.g. a surf kite).

Buildings, property or land not at the insured address

You owning, occupying or leasing any building, property or land **except** for:

- › your home and domestic land at the insured address **when you insure your home under this policy**
- › the unit you live in at the insured address and the common areas around the unit, **when you insure your contents in the unit under this policy**
- › the additional cover for a vacant lot of land shown on page 35.

Business activity

Any business activity except:

- › accommodating boarders or bed-and-breakfast guests in your home or unit, but only if:
 - › no more than **2** bedrooms are let for this purpose **and**
 - › you still live at the insured address
- › part-time casual babysitting where you do not need to be registered or licenced to do this.

Caravans and trailers

Using or owning a caravan, mobile home or trailer.

Committee members or officials

Your actions or duties as a committee member or director of a club or association, as a coach, referee or official at a game or organised sporting activity.

We do not cover legal liability caused by or resulting from:

Committing an offence or breaking the law

You or any person insured under the policy or a person acting with your given or implied consent:

- committing or trying to commit an unlawful or criminal offence, such as supplying illegal substances or drugs, assault or malicious damage
- not obeying any commonwealth, state, territory or local government law, including laws relating to:
 - installing smoke alarms
 - pool fencing
 - failing to install a balcony railing or balustrade when required
 - dangerous goods and liquids
 - firearms
 - control and safekeeping of dangerous or restricted breeds of dogs, including not obeying any legal requirement to restrain a dog in public or keep it fenced in.

Death or injury

Death or injury of:

- you
- a child (born or unborn) under **18** years who is your child or the child of your spouse, de facto or partner
- your pets
- anyone who usually lives with you in the home or unit unless:
 - the person is a paying boarder or bed-and-breakfast guest in your home or unit and is not your child or the child of your spouse, de facto or partner **and**
 - no more than **2** bedrooms are available for accommodating boarders or guests.

Deliberate act or lack of action by you

Any act by you or by someone acting with your given or implied consent that is:

- deliberate
- demonstrates a reckless disregard for the consequences of that action
- a deliberate lack of action.

Disease or illness

Exposure to or disease caused by asbestos in any form or a disease, illness or sickness you knowingly spread or failed to take due care to prevent spreading after you knew about it.

We do not cover legal liability caused by or resulting from:

Illegal drugs

An incident which:

- occurred when you were under the influence of, or your judgment was affected by, any illegal substance or drug or
- you caused or contributed to because you possessed, supplied or consumed illegal substances or illegal drugs.

Legal action in other countries

Legal action or legal claims brought against you, decided or heard in countries outside Australia or New Zealand.

Libel or slander

Libel or slander.

Motor vehicles or motor cycles

The use or ownership of a motor vehicle or motor cycle (see meaning on page 73) or instructing someone on how to use it unless at the time of the incident, it was being used legally and did not have to be insured under any compulsory third party insurance laws and was:

- a remote-controlled model car
- a wheelchair or a mobility scooter designed to accommodate physical disabilities or the elderly
- a golf cart or buggy
- domestic gardening equipment (e.g. a ride-on mower).

Property owned by you or property in your legal custody or owned by your employer

Damage to property which:

- is owned by you or your family, or anyone who usually lives with you in the home or unit
- belongs to someone else and is in your physical and legal custody or control
- is owned by your employer (e.g. you accidentally damage office equipment at your work place),

but we will cover your legal liability under a tenancy rental agreement contract when your contents in your landlord's residential property are insured under your policy, for damage caused by:

- water leaking from pipes, washing machines, dishwashers or water overflowing from blocked baths or tubs
- fire damage to your landlord's property.

Watercraft

Using or owning any watercraft unless it is a sailboard, surfboard, wave board, canoe, kayak, non-motorised surf ski or remote-controlled model watercraft.

Your employees

Death or injury of your employees or damage to their property while they are working for you.

Claims

Making a claim

When to make a claim

Contact us as soon as possible if you suffer loss or damage, or there is an incident that could result in a claim.

How to make a claim

Step 1	<p>Make sure everyone is safe. For emergencies, please call 000.</p>
Step 2	<p>Immediately report any theft and malicious damage to the police. Give them a list of all stolen or damaged items. Keep details of the date reported, name of the police officer, police station reported to and the report number.</p>
Step 3	<p>Try to prevent further loss, damage or injury You must do everything you reasonably can to prevent further loss, damage or liability (e.g. if there is a hole in the roof, arrange for it to be covered to prevent further water damage from rain).</p>
Step 4	<p>Contact us without further delay on 13 14 46. We're available 24 hours a day. You can also lodge your claim online (gio.com.au) and a consultant will return your call. If you delay reporting your claim, we will not pay for any additional loss or damage caused by your delay. Describe details of what has been affected by the event (e.g. a broken window, storm damage or a list of stolen items). For electrical items, please have details about the make and model handy.</p>

For customers who are registered for GST

If we ask you for this, you must tell us about any Input Tax Credits (ITC) you are entitled to for your premium and claim. If you don't, we will not pay any resulting fines, penalties or tax charges incurred by you. When we calculate a payment to you for your claim, we can reduce it by any input tax credits you are, or would be, entitled to receive.

Legal liability claims

Tell us about any incident that has caused an injury to others or damage to other people's property.

You also must immediately tell us about any demands made on you to pay compensation to others and send these to us, and any court documents, letters of demand or offers of settlement.

If you make a legal liability claim that is covered under this policy we can decide to defend you, settle any claim against you or represent you at an inquest, official enquiry or court proceedings.

If we decide to defend you, settle any claim against you or represent you, then you must give us all the help we need, including help after your claim has been settled.

For information on additional feature 20 (legal liability) see page 35.

What you must not do

When an incident occurs which could result in a claim:

- do not get rid of damaged parts of your home or contents without our consent
- do not carry out or authorise repairs without our consent unless you cannot contact us and the repairs are necessary to protect your home or contents from further loss or damage
- do not wash or clean or remove debris from any area damaged by fire without our consent unless you need to do this to prevent further loss or for sanitation
- do not admit liability or responsibility to anyone else unless we agree
- do not negotiate, pay or settle a claim with anyone else unless we agree.

If you do not comply

If you do not comply with 'How to make a claim' and 'What you must not do' we can reduce or refuse your claim.

If we decline a claim

We will provide reasons for our decision to decline and if your claim is lodged, we will send you written confirmation. If you wish to dispute our decision, see page 75 for more information.

Definition of proofs

These terms are used in the following pages and are defined below.

Proof of purchase

Includes documents such as sales receipts or debit details on a credit card or bank statement. The proof of purchase should include the item description or code, a purchase price, date purchased and where the item was purchased.

Sales receipt

Includes the item description or code, a purchase price, date purchased and where the item was purchased.

Full description

The specifications particular to an item (e.g. brand and model for an electrical appliance or the title and artist of a CD).

Valuation

A document completed by an Australian qualified professional valuer before the loss occurred. This includes an item description, specifications and the cost to replace the item in Australian dollars.

Close-up photograph

A photograph taken from one metre away from the item(s) that clearly shows the item(s).

Original operating manual

The original printed operation manuals that came with the item.

Manufacturer's box

The original box showing brand and model of the item.

Certificate of authenticity

The original documentation from the manufacturer.

Minimum proofs of ownership and value

We require proofs when items are lost, stolen or badly damaged. Whilst we understand it is not practical to keep proofs for every household item you own, there are items we do expect minimum proofs for and these are described on the following pages. If you do not provide the required minimum proof of ownership set out in these tables for these items, we may refuse your claim. We have the right to ask you for more proofs and if so, we will let you know.

Jewellery

Amount claimed for each item or set	Minimum proofs for assessment
up to \$500	Details of when and where purchased and the price paid. If you are claiming for more than \$1,000 in total, we may ask you for more proofs.
over \$500 to \$1,000	One of the following: <ul style="list-style-type: none"> ➤ proof of purchase that identifies the item ➤ a close-up photograph clearly showing the item ➤ a full description and value from a jeweller obtained before the loss occurred.
over \$1,000 to \$3,000	<ul style="list-style-type: none"> ➤ proof of purchase that identifies the item plus ➤ a full description of the item in writing from the jeweller you bought it from or a professional valuer.
over \$3,000	<ul style="list-style-type: none"> ➤ A valuation by a qualified jeweller or professional valuer. A close-up photograph will help us but is not essential.

When you receive jewellery as a gift

Obtain valuations from an Australian qualified jeweller or professional valuer showing the cost to replace the item plus a full description so you can provide proof of value in case you make a claim.

Watches

Amount claimed for each watch	Minimum proofs for assessment
up to \$1,000	<p>If purchased over 12 months ago</p> <p>Details of when and where purchased and the price paid.</p> <p>If purchased new in the last 12 months</p> <p>One of the following:</p> <ul style="list-style-type: none"> ➤ proof of purchase that identifies the item ➤ a certificate of authenticity ➤ an original operating manual ➤ the manufacturer's box ➤ a close-up photograph.

Watches

Amount claimed for each watch	Minimum proofs for assessment
over \$1,000 to \$2,000	<p>One of the following:</p> <ul style="list-style-type: none"> ➤ proof of purchase that identifies the item ➤ a certificate of authenticity ➤ an original operating manual ➤ the manufacturer's box ➤ a close-up photograph.
over \$2,000	<p>One of the following:</p> <ul style="list-style-type: none"> ➤ proof of purchase that identifies the item ➤ a warranty, guarantee or certificate of authenticity showing the model or serial number ➤ a manufacturer's box if it has the model or serial number showing ➤ a valuation by a licenced member of the Auctioneers and Valuers Association of Australia.

CDs, DVDs, records and other types of music, video and electronic media and storage items

Amount claimed for each item or set	Minimum proofs for assessment
up to \$1,000 in total	A list of items claimed and their replacement cost.
over \$1,000 in total	<ul style="list-style-type: none"> ➤ A list of items claimed plus ➤ photographs that clearly show the number of claimed items in the place where they are stored.

Paintings, pictures, works of art, sculptures and art

Amount claimed for each item or set	Minimum proofs for assessment
up to \$2,000	<p>If purchased over 12 months ago Details of when and where purchased and the price paid.</p> <p>If purchased new in the past 12 months Proof of purchase that identifies the item.</p>
over \$2,000	<p>One of the following:</p> <ul style="list-style-type: none"> ➤ proof of purchase that identifies the item ➤ a valuation by the Auctioneers and Valuers Association of Australia.

Silver or gold items, items plated with silver or gold (other than jewellery and watches)

Amount claimed for each item or set	Minimum proofs for assessment
up to \$1,000	<ul style="list-style-type: none"> ➤ a full description plus ➤ details of when and where each item was purchased and the price paid.
over \$1,000	<p>One of the following:</p> <ul style="list-style-type: none"> ➤ proof of purchase showing a full description of each item or set ➤ proof of value from a professional valuer or dealer. <p>A close-up photograph will help but is not essential.</p>

Stamp, stamp collections, collector's pins, medals and collector's non-negotiable currency

Amount claimed for each item or set	Minimum proofs for assessment
up to \$2,000	<p>If purchased over 12 months ago Details of when and where purchased and the price paid.</p> <p>If purchased new in the past 12 months Proof of purchase that identifies the item.</p>
over \$2,000	<p>One of the following:</p> <ul style="list-style-type: none"> ➤ photos or photocopies of each coin or stamp plus evidence of what it is worth ➤ proof of purchase that identifies the item ➤ a valuation by the Auctioneers and Valuers Association of Australia.

Electrical items such as televisions, stereos, cameras, mobile phones, computers, PDAs and organisers

Amount claimed for each item	Minimum proofs for assessment
up to \$250	<p>If purchased over 12 months ago Details of when and where purchased and the price paid for it.</p> <p>If purchased new in the past 12 months One of the following:</p> <ul style="list-style-type: none"> ➤ proof of purchase that identifies the item ➤ original operating manual ➤ manufacturer's box.
over \$250	<p>If purchased over 5 years ago We will decide what is reasonable proof of ownership depending on what is claimed, its age and value.</p> <p>If purchased new in the past 5 years One of the following:</p> <ul style="list-style-type: none"> ➤ proof of purchase that identifies the item ➤ original operating manual ➤ manufacturer's box.

Collections or memorabilia

Amount claimed for each item or set	Minimum proofs for assessment
up to \$2,000	<p>If purchased over 12 months ago Details of when and where purchased and the price paid.</p> <p>If purchased new in the past 12 months Proof of purchase that identifies the item.</p>
over \$2,000	<p>One of the following:</p> <ul style="list-style-type: none"> ➤ photos or photocopies plus evidence of what it is worth ➤ proof of purchase that identifies the item ➤ a valuation by the Auctioneers and Valuers Association of Australia.

Carpet or rugs that are handwoven

Amount claimed for each item	Minimum proofs for assessment
up to \$2,000	<p>If purchased over 12 months ago Details of when and where purchased and the price paid.</p> <p>If purchased new in the past 12 months Proof of purchase that identifies the item.</p>
over \$2,000	<p>One of the following:</p> <ul style="list-style-type: none"> ➤ proof of purchase that identifies the item ➤ a valuation by the Auctioneers and Valuers Association of Australia.

For all other items

We will decide what is reasonable proof of ownership and value depending on what you are claiming for, how old they are and their value.

When you cannot supply required proof

If you are unable to reasonably substantiate your claim, we can reduce or refuse your claim.

How to establish your loss**Establish an incident took place**

When making a claim you must be able to prove that an incident insured by your policy actually took place. If you do not do this, we will not be able to pay your claim.

Describe your loss or damage

You must also give us accurate and full details of what was lost, stolen or damaged and give us proof of value and ownership for items claimed.

When your home or contents are damaged

Usually allowing us, a repairer or an expert appointed by us, to look at what is damaged is all that is needed to prove your loss. For valuable and badly damaged items, we may ask you to provide proof of ownership and value.

How to prove ownership and value

For lost, damaged or stolen items that are no longer available for inspection, you are required to validate your claim by giving us details of when and where purchased and reasonable proof of ownership and value.

We have minimum proof requirements for items such as paintings, jewellery, electrical items and DVDs. For full details of these requirements see pages 53 to 56. We have the right to reject your claim for an item if you do not provide the minimum proof requirement for that item. We have the right to ask you for more proofs and if so, we will let you know.

Where a valuation is required, we will only accept Australian valuations.

For all other items, we will decide what is reasonable proof of ownership and value depending on what you are claiming for, how old they are and their value.

If you are unable to reasonably substantiate your claim, we can reduce or refuse your claim.

Things you must do

- allow us to inspect the damaged home or contents, including to investigate the cause of the loss and to assess your claim
- allow us to arrange for experts to assess the damaged home or contents and to quote on repair or replacement
- provide us with a quote for repair or replacement if we ask for this. If you choose to use our recommended repairers (when available), there is no need to obtain your own quotes
- consult an expert if we ask for this and provide any information the expert requests.

Your co-operation is extremely important. If you do not co-operate we may reject your claim, or we may be unable to assess and pay your claim.

Your excess

What is an excess?

An excess is the amount you have to pay for each incident when you make a claim. We will deduct the excess from the amount of cover provided by your policy for the loss. The amount and types of excesses are shown on your certificate of insurance.

The types of excesses are:

- › **Basic excess** – This excess applies to all home and contents claims except for portable or optional cover claims. You can choose your basic excess from the range we offer.
- › **Optional cover excess** – Some optional covers have their own excess. If an optional cover does not have its own excess then the basic excess applies.
- › **Earthquake and tsunami excess** – When loss or damage is caused by an earthquake or tsunami, you pay this excess in addition to any other excesses that applies.
- › **Additional excess** – Sometimes we might decide to impose an additional excess. There are a range of reasons why we might decide to impose an additional excess. If an additional excess applies it applies on top of any other excesses.

When multiple excesses apply

Depending on the circumstances, you might have to pay more than one type of excess when you claim.

One excess to pay when you claim for home and contents

If you have a claim for both home and contents for the same insured incident, we will calculate the excesses that apply to your home and contents separately. You do not have to pay both, you only pay the higher of the two amounts. You must pay the excess in full.

More details

For further details about our excesses, please refer to our Premiums, Excesses, Discounts and Claim Payments Guide available at gio.com.au/moredetails. A copy of this guide can be provided to you on request, at no charge, if you contact us on 13 10 10.

How to pay your excess

If your claim is approved, we will:

- › ask you to pay your excess to a repairer or supplier **or**
- › ask you to pay us the excess **or**
- › deduct the excess from the amount of cover for the insured loss and pay your claim.

How we settle your claim

We choose how your claim is settled

If we agree to pay a claim for loss, theft or damage to your home and contents we will decide if we will:

- › repair damage new for old **or**
- › replace home or contents new for old **or**
- › pay you what it would cost us to repair or replace your home or contents new for old.

The meaning of new for old is defined below.

We will not:

- › pay extra to replace your home or contents to a better standard, specification or quality than it was before the loss or damage occurred except as stated in 'new for old' below
- › fix a fault that existed before the loss or damage occurred.

New for old means:

› new materials, new items

we replace or repair with new items or new materials that are available at the time of replacement or repair from Australian suppliers.

› new for old, regardless of age

we replace or repair new for old regardless of age, with no allowance for depreciation.

For example, a leather lounge which was purchased 5 years ago for \$5,000 and now worth \$2,000, will be replaced with a brand new leather lounge equivalent to your old lounge when it was new. Cover is not limited to **\$2,000**.

› same type, standard and specification as when new

we replace or repair to the same type, standard and specification as when new. If the same is not available, it means of a similar type, standard and specification when new. It can be a different brand.

New for old does not:

- › include paying the extra cost of replacing or purchasing an extended warranty on any home or contents item **or**
- › mean of a better standard, specification or quality than when new.

When items may be replaced to a better standard

Refrigerators, freezers, dishwashers, air conditioners, washing machines and dryers with less than a 3 star energy rating

For these items when being replaced, new for old means replacing with a new item of equal specification and if you agree, it means replacing with a minimum 3 star energy rating if this is available. It can be a different brand.

Obsolete electrical appliances

For obsolete electrical appliances, such as outdated computers or TVs, new for old means replacing or repairing to an equal specification. If this is not available, it means to the nearest better specification available. It can be a different brand.

When items cannot be replaced new for old

Paintings, pictures, works of art, sculptures, art objects, collections, memorabilia and antiques (not jewellery)

For these items, new for old means that if the item cannot be replaced or repaired new for old, we will pay you what it would have cost to buy the item immediately before the loss or damage occurred, but we will not pay more than its sum insured for that item.

When the sum insured is not enough to pay a claim

Pro rata adjustment of the sum insured

At renewal, we will adjust your total home and contents sum insured to accommodate increases in building and replacement costs. If you make a claim part way through the period of insurance, we will bring forward this adjustment using the following formula. We will:

- + increase the sum insured by the current annual adjustment of the sum insured at the time of the loss or damage and
- subtract from this an amount for unused period of insurance.

The adjustment will not apply to any listed contents items.

For example

If your home is under-insured and is destroyed by fire after **6** months period of insurance and the current annual adjustment we are using is **10%**, then we would increase your sum insured by an annual adjustment of **5%**.

This is on the basis that only half your period of insurance has been used, so you are entitled to half the annual automatic adjustments to the sum insured.

If you are still under-insured

Home claims

If the home sum insured after the pro rata adjustment is not enough to repair or rebuild your home, then we will add the cover provided by additional feature 2b (safety net home protection) (see page 22).

If you are still under-insured after the pro rata adjustment and safety net home protection, then we will pay you the adjusted home sum insured plus any cover available under safety net home protection. We will not arrange repairs or replacements.

Contents claims

If the contents sum insured after the pro rata adjustment is not enough to repair or replace your contents, then we will pay you the contents sum insured.

Home claims

How we settle home claims

If we agree to pay a claim for loss, theft or damage to your home, we will decide if we will:

- › repair damage new for old **or**
- › rebuild your home new for old **or**
- › pay you what it would cost us to repair or rebuild your home new for old.

When we repair or rebuild your home

We will do our best to obtain new materials that are the same type, standard and specification as when new. If the same is not available, we will use new materials of a similar type, standard and specification that are commercially available and compliant with the latest building regulations.

When we cannot match materials

If we cannot find new materials to match undamaged parts, we will use the closest match available to us.



If you are not satisfied with the materials we find as the closest match:



If we agree, you can pay the extra cost of replacing undamaged parts of the home to achieve a uniform appearance.



Or we will pay you what it would have cost us to repair or rebuild the damaged part.

Repairing or rebuilding damaged parts

We will only repair or rebuild the parts that are damaged by an insured incident. You cannot claim to replace undamaged parts of your home to create a uniform appearance, such as when:

- › **one garage door is damaged**
we will only replace or repair the damaged one, not other doors
- › **roof tiles are damaged**
we will only replace the damaged ones, not the undamaged tiles, even if the undamaged tiles are faded and do not match the new ones used for repairs
- › **roof sheeting is damaged**
we will only replace the damaged roof sheeting, not the undamaged roof sheeting, even if the closest match available to us is a different shade or colour to the undamaged roof sheeting
- › **an external wall is damaged**
we will replace the damaged parts of the wall, not undamaged areas of the wall or other sides of your home.

For circumstances where we will repair or rebuild undamaged parts read the following pages.

When we will repair or rebuild undamaged parts

If we cannot match the new materials with the undamaged parts, if necessary, we will only pay extra to create a uniform appearance when:

› wall tiles are damaged

we will pay up to **\$750** extra for each incident to replace undamaged wall tiles in the same room, stairs, hallway or passageway* so they match or complement new tiles used for repairs

› other wall coverings are damaged

(e.g. paint, wallpaper, wood panels, but not tiles) we will pay extra to paint, wallpaper or replace undamaged wall coverings in the same room, stairs, hallway or passageway where the damage occurred

› floor coverings are damaged (including tiles)

we will pay extra to replace continuously joined undamaged floor coverings of the same material in the same room, stairs, hallway or passageway where the damage occurred

› kitchen cabinets, cupboards or benchtops are damaged

this is described on the next page.

*For definitions of these terms refer to the diagrams on pages 63 to 64.

Repairing or replacing kitchen cabinets, cupboards or benchtops

We will repair damaged parts of your kitchen

We will repair the damaged parts of your kitchen cupboards, cabinets or benchtops.

When we will replace undamaged parts of the kitchen

To create a uniform appearance, if necessary, we will pay extra to replace undamaged parts of the same cupboard, cabinet or benchtop so that they match the repaired parts.

Same cabinet, cupboard or benchtop means:

- › those parts continuously joined to the damaged parts (this is one 'section')
- › made out of the same materials **and**
- › on the same level.

See the case study on the next page for a visual explanation.

Note

Sometimes replacing the benchtop, door fronts or drawers in the undamaged area is all that is necessary to create a uniform appearance. We will decide what is necessary depending on the circumstances.

Case study

The extent of repairs carried out to match undamaged areas in a kitchen.

To match undamaged areas to the damaged parts, they must be:

- continuously joined and
- on the same level and
- made of the same material.

In this kitchen case study

Areas 1, 2 and 3 will be treated as separate sections. The oven breaks up the bottom level into two sections (e.g. if only section 2 is damaged, we will not pay to replace sections 1 and 3).

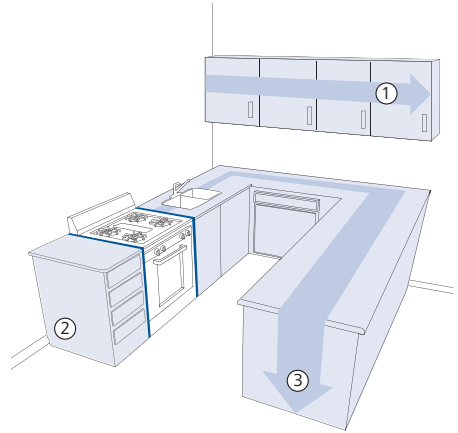

What we mean by same room, stairs, hallway or passageway

Same room

A room is an area starting and finishing at:

- its nearest walls
- nearest doorway, archway or similar opening of any width
- a change in the floor or wall covering.

A hallway next to a room is not the same room, even if it has the same floor or wall covering as the room.

Any archway or similar opening separates a room unless it is a combined lounge-dining room (below).

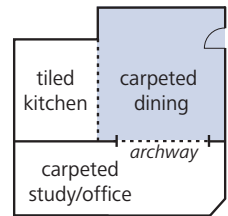

Combined lounge-dining room

We will only combine rooms with a shared doorway, archway or similar opening when:

- they are lounge and dining rooms and
- the shared doorway, archway or similar opening is wider than 82cm and
- the floor or wall covering is the same in both rooms.

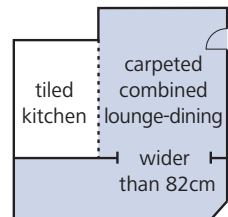

Open plan areas

When there is no wall, archway, doorway or similar opening, the room continues until:

- a change in the floor or wall covering
- the nearest wall, doorway, archway or similar opening.

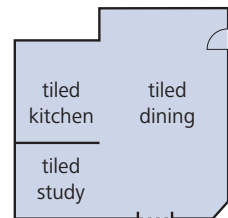

Same passageway or hallway

A passageway or hallway has the same meaning as a room. We will not combine a hallway and a room.

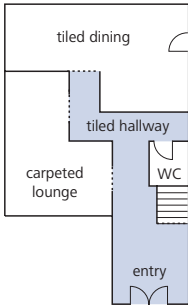

Same stairs

Side view of stairs

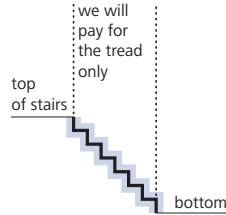

Legend

- Shaded areas show the area that we consider the same room, stairs, hallway or passageway.
- Solid lines represent floor to ceiling walls.
- - - Dotted lines show boundaries of a room or area where there is no physical barrier present (e.g. no wall or door).

Dealing with defects

If a known defect is the cause of the damage

We do not pay for loss or damage caused by a defect, structural fault or design fault at your home that you knew about (or should reasonably have known about) and did not fix before the loss or damage occurred.

If an unknown defect is the cause of the damage

If an insured incident damages your home and an unknown defect was the cause or part of the cause, we will pay for the resulting damage. If the unknown defective part is also damaged by the same incident, we will fix this as well.

We do not rectify structural or design faults

When we accept a claim, we will not pay extra to rectify a structural or design fault at your home that existed before the damage occurred. We will only pay you what it would have cost us to fix the damage from the insured incident or if we agree, you can pay us extra to rectify the structural or design fault at your home.

If undamaged defective parts of your home will not support repairs

If undamaged defective parts of your home will not support repairing damage by an insured incident, we will only pay what it would have cost us to repair the damage had your home not been defective.

For known defects or faults

Once you become aware of a defect, structural or design fault at the home, you must rectify it as soon as possible because there is no cover for loss or damage due to that defect. If you do not rectify the defect or fault, we will not offer a renewal of your policy.

Changes to your home

If you want to change the design of your home

When rebuilding your home, if we agree, you can choose to change the design of your home or upgrade parts of it, providing you pay the extra costs of doing this. If you want to downsize your home for less cost than you are entitled to claim, we will not pay more than it costs us to rebuild the downsized home.

Choosing to rebuild on another site

If your home is to be rebuilt after an insured incident you can choose to have your home rebuilt on another site providing you pay any extra costs involved.

Homes to be demolished

If you planned to demolish your home before it was damaged by an insured incident, we will only pay you the demolition value of your home. Without written evidence of your home's demolition value, we will not pay your claim if your home is damaged by an insured incident.

The demolition value is the amount you would have received for parts of your home had you sold them when your home was being demolished.

Planned means you intended to demolish your home, had lodged an application to do this, or a government authority had issued a demolition order.

Lifetime guarantee on home repairs

When we repair or rebuild your home, we guarantee the quality of materials and workmanship of that work for the lifetime of your home if we:

- › authorise **and**
- › arrange **and**
- › pay the builder or repairer directly for this work.

What we guarantee

We guarantee the material used and standard of the workmanship to be free of defects. If a defect arises in the lifetime of your home as a result of poor quality workmanship or use of incorrect materials, then we will rectify the problem.

This guarantee does not apply:

- › to repairs you authorise or make yourself
- › to loss, damage or failure of any electrical or mechanical appliances or machines
- › to wear and tear consistent with normal gradual deterioration of your home (e.g. paint peeling off after its expected life cycle, wood rotting from moisture in the air or ground, roofs weathering or a hot water tank leaking after its guaranteed life)
- › where we agree with a repair quote and we give you, or the builder or repairer, a cheque for the cost of the repairs and you arrange the repairs.

Contents claims

How contents claims are settled

If we agree to pay a claim for loss, theft or damage to your contents, we will decide if we will:

- repair damage new for old **or**
- replace your contents new for old **or**
- pay you what it would cost us to repair or replace your contents new for old.

When we repair or replace your contents

We will repair or replace your contents with new items or new materials that are reasonably available at the time of replacement or repair from Australian suppliers. We replace to the same type, standard and specification as when new. If the same is not reasonably available, it means of a similar type, standard and specification when new. It can be a different brand.

When we cannot match materials

If we cannot find new materials to match undamaged parts, we will use the closest match available to us.



If you are not satisfied with the materials we find as the closest match:



if we agree, you can pay the extra cost of replacing undamaged parts of your contents to achieve a uniform appearance.



Or we will pay you what it would have cost us, but only if we agree to this. We usually insist on replacing jewellery if your cover is adequate.

If you have a claim for the following items:

- obsolete electrical appliances
- paintings, pictures, works of art, sculptures, art objects, collections, memorabilia and antiques (not jewellery)
- refrigerators, freezers, dishwashers, air conditioners, washing machines and dryers with less than a 3 star energy rating

please see pages 59 to 60 for details on how we settle these claims.

Repairing or replacing damaged contents

We will only repair or replace contents that are lost or damaged by an insured incident. You cannot claim to replace undamaged parts of your contents (e.g. when a lounge chair which is part of a suite is damaged beyond repair. We will pay to replace that chair, not the whole lounge suite).

When we will repair or replace undamaged parts

We will pay extra to create a uniform appearance when the following are damaged:

› internal blinds and curtains

if we can't match the new material or parts with the undamaged ones, if necessary, we will pay extra to replace undamaged blinds and curtains in the same room, stairs, hallway or passageway* where the damage occurred.

› carpet or other floor coverings

if we can't match the new material or parts with the undamaged ones, if necessary, we will pay extra to replace undamaged floor carpet and other coverings in the same room, stairs, hallway or passageway where the damage occurred.

*For definitions of these terms refer to the diagrams in the section 'Home Claims' on pages 63 to 64.

Does your claim affect your cover?

After a home claim

If we only pay part of the sum insured to you, your home policy continues for the period of insurance.

If we pay the full sum insured to you, all cover under your home policy stops. There is no refund of the unused premium. If you have been paying premiums by monthly instalments, we will deduct the remaining instalment premiums for the unexpired period of insurance, from the amount we pay for the claim.

After a contents claim

If we pay the full sum insured on your contents after a claim, your contents sum insured is automatically reinstated and cover continues for the period of insurance at no extra cost. You may need to change your insured address or change your contents sum insured. There is no refund of premium if you reduce your sum insured by the amount of your claim.

After claiming for listed contents

If we pay you the sum insured for a listed content item (e.g. a \$5,000 engagement ring), or pay to replace it, cover for that item stops and there is no refund of unused premium. If you want cover for any new replacement item, you will need to contact us and apply for cover for the new item.

What we will do after a claim is paid

Salvaged home contents

We can take and keep any recovered or salvaged item and sell it and keep the proceeds after we have replaced the item or paid you for it.

Our right to recover claims we pay from those responsible

After we pay a claim under this policy, we can decide to take legal action in your name to recover money from the person or entity that caused loss, damage or liability. You must give us all the help we need to do this. If we recover money that belongs to you and was not part of the claim we paid, we will give this to you.

More details

For further examples on how a claim payment might typically be calculated, please refer to our Premiums, Excesses, Discounts and Claim Payments Guide available at gio.com.au/moredetails. A copy of this guide can be provided to you on request, at no charge, if you contact us on 13 10 10.

Other Important Information

Your responsibilities

You must:

- keep the home, unit and contents well maintained and in good condition, this includes rectifying faults or defects such as fixing roofs, gutters, drains, water pipes and tiled areas when they leak or need repairs
- maintain locks or alarms in good working condition, especially if we relied on burglary security or monitored smoke detectors being installed when accepting your insurance
- take all reasonable care to prevent theft, loss, damage or legal liability
- follow all the terms and responsibilities set out in your policy
- provide honest and complete information for any claim, statement or document supplied to us.

Not meeting your responsibilities

If you do not meet your responsibilities, we may:

- reduce or refuse to pay your claim **or**
- cancel your insurance policy.

If fraud is involved, we can treat your policy as if it never existed.

When you need to call us

When your home will be unoccupied

When your home will be unoccupied for more than **100** consecutive days all cover stops unless, before the home became unoccupied, we agree in writing to continue cover, and you:

- secure the home or unit against intruders (e.g. window locks or deadlocks) if we ask for this
- install a monitored alarm with smoke detectors if we ask for this
- arrange for your mail to be collected, all regular deliveries cancelled, the lawns and gardens to be maintained, a weekly inspection and any required maintenance while you are away
- pay us any extra premium we require for the increased risk **and**
- agree to any increased excess that we impose.

When you alter, extend or renovate your home

When you plan to alter, extend or renovate we will not cover you for some insured incidents.

Your legal liability cover is also affected if you spend more than **\$100,000** on building, altering or renovating.

You must also contact us when:

- you become aware that your home has a defect or is in a state of disrepair (e.g. the roof leaks when it rains)
- you plan to demolish your home. You must obtain written evidence of your home's demolition value. 'Plan' means you intend to demolish your home, have lodged an application to do this, or a government authority issued a demolition order
- you move out and let your home to tenants

- › trespassers (squatters) occupy your home
- › you are operating or intend to operate a business activity at your home **except** there is no need to tell us about letting **1** or **2** bedrooms to paying guests, boarders or tenants or using **1** or **2** rooms as a home office
- › details on your certificate of insurance are no longer accurate.

What we will do when you contact us

We will re-evaluate your policy. We might decide to:

- › to continue cover with no changes to your policy **or**
- › offer to continue cover with an additional excess, charge an additional premium or impose special condition to your policy **or**
- › cancel your policy.

We will advise you of our decision in writing.

What happens with cancellations?

Cancellation by you

You can cancel the cover at any time and the cancellation takes effect on the date we receive your request. We will refund any money we owe you less any cancellation fee that might apply and any non-refundable government charges.

Cancellation by us

We can cancel your cover at any time according to law. We will refund any money we owe you less any non-refundable government charges. If we cancel your policy due to fraud, we will not refund any money to you.

Cancellation fee

We incur costs in establishing and administering your policy. If you cancel one or more insured addresses on your policy within the same period of insurance, we will charge a fee.

A cancellation fee will not apply if:

- › you are transferring cover to another home or contents policy with us
- › you are moving to an area where we do not offer insurance
- › you cancel the cover within the cooling off period
- › we cancel the cover for any reason.

Your cancellation fee is based on the number of days remaining in your period of insurance for the address being cancelled. The maximum amount charged on each cancelled insured address is **\$80** (inclusive of government charges), and this amount reduces daily to a minimum of **\$30** (inclusive of government charges).

This fee is deducted from any refund we send you. If the refund is less than the fee, a refund will not be issued and we will not charge you an additional amount to cover the difference.

For policies paid by the month, no refund will be issued.

Terms explained

The following list explains the meaning of terms used in this policy. When any of the following terms appear in this policy, regardless of whether their first letter is a capital or in lower case, their meaning is shown on the following pages.

accident

An incident you did not intend or expect to happen.

actions or movements of the sea

Includes:

- › rises in the level of the ocean or sea
- › storm surge
- › sea waves
- › high tides or king tides
- › any other actions or movements in the sea.

Actions or movements of the sea does not include a tsunami.

aircraft

A machine or craft designed to fly or glide in the air.

at the home or at the insured address

For at the home, it means within the home's domestic land boundaries located at the address shown on your certificate of insurance.

For a unit, it means in the unit where you have insured your contents under this policy.

boarder or bed-and-breakfast guest

A person who pays to live in your home with you.

business activity

A business, trade, profession, occupation or any income-earning activity where that income needs to be declared to the Australian Taxation Office. A business activity also includes farming, grazing, agistment of stock or agriculture that earns you money. It does not mean the tenancy of your home or receiving income from bed-and-breakfast guests or boarders if no more than **2** bedrooms at the home or unit are let for this purpose.

certificate of insurance

The latest certificate of insurance we have given you. It includes your insurance account. It is an important document as it shows the covers you have chosen and other policy details such as the premium that applies.

collection

A number of items that, by being gathered together according to some underlying principle, has a greater value than the total value of all the individual items.

common areas

Anywhere on the common property according to the strata, body corporate, unit title or similar law in the state or territory in which the insured address is located.

compensation

Money you are legally liable to pay as a result of:

- › a judgement made against you by a court of law **or**
- › a settlement by us of legal action against you.

It does not include fines, penalties, punitive, aggravated or exemplary damages.

computers

An electronic digital device that stores, retrieves and processes data, and can be programmed with instructions. It includes devices such as a PC, laptop, electronic notebook and a PDA. A computer is composed of hardware and software, including:

- › CPU
- › monitor
- › processor
- › hard drive
- › keyboard and mouse.

contents

Your contents shown as insured on page 11.

duty of disclosure

You have a Duty of Disclosure to tell us everything you know or should know, that is relevant to our decision to insure anyone under the policy, including you, and on what terms.

It includes matters we specifically ask about when you apply for a policy, or renew or alter your policy, and any other matters which might affect whether we insure you and on what terms.

The information you tell us can affect:

- › the amount of your premium
- › if we will insure you
- › if special conditions will apply to your policy.

You do not need to tell us of anything which:

- › reduces the chances of you making a claim **or**
- › we should know about because of the business we are in **or**
- › we tell you we do not want to know.

If you are unsure it is better to tell us. If you do not tell us something which you know or should know is relevant, we might reduce a claim, refuse to pay a claim, cancel your policy or, if fraud is involved, we can treat the policy as if it had never existed.

excess

See 'Your excess' on page 58.

family or your family

Your spouse, your partner or your de facto who lives with you, your parents and parents-in-law, your children or your spouse's children, your brothers and your sisters.

fixed

Things permanently attached to the home or permanently anchored in the ground that when removed leave holes or damage.

flood

Inundation caused by rain falling over land resulting in water pooling, overflowing or spreading from:

- › naturally occurring or man-made inland water courses such as rivers, creeks, canals, lakes, ponds, dams and reservoirs

- › wet areas of land (e.g. marshes)
- › dry roads and streets
- › normally dry areas of land.

Flood also includes water escaping, overflowing or being released from a dam or reservoir.

Flood is not:

- › water from actions or movements of the sea
- › a mixture of water from actions or movements of the sea combined with water from any other source.

forcible entry or forced entry

Unlawful entry into the home or unit, including entry by using stolen keys or picking locks. It does not mean opening an unlocked door or window.

home

Your home shown as insured on page 9. For 'at the home or at the insured address' see page 71.

home office

A room or part of the home used as an office for business activities.

home office equipment

The following office equipment if used for a business activity (part time or full time):

- › computers and their accessories including laptops, electronic diaries, palm or pocket PCs, printers and scanners (but not software, games or stored media information)
- › filing cabinets
- › fax machines and photocopiers
- › phones
- › chairs, tables, desks and other office furniture.

incident or event

A single occurrence which is not intended or expected to happen by you.

insured address or at the insured address

For your home, it means within your home's domestic land boundaries located at the address shown on your certificate of insurance.

For a strata title unit, it means in the unit you own or live in.

For a non-strata residential flat, it means in the flat you live in.

interim cover

Insurance cover we give you before your certificate of insurance is issued. When we issue your certificate of insurance, it will include the period of interim cover.

limit

The most you can claim for any one incident. It includes GST.

living and lives in

Someone occupying a home and eating and sleeping there.

malicious damage

Deliberate or intentional damage, including vandalism. It also includes damage caused by a person assaulting another person or committing suicide or murder.

memorabilia

An item collected for the sake of memory that has extra value for a collector in addition to its material value.

mobile home

A motor vehicle designed to accommodate people overnight and be driven on a road.

motor cycle

A single, two or three wheeled vehicle that is powered or partly powered to move by its own motor. Motor cycle includes these vehicles or any of their accessories or spare parts:

- motor cycles and mini-motor cycles
- motorised scooters, motorised bicycles and motorised skateboards but not mobility scooters designed to accommodate physical disabilities or the elderly.

motor vehicle

A vehicle that moves by the power of its own motor. Motor vehicle includes these vehicles or any of their accessories or spare parts:

- sedans, utilities, trucks, prime movers and trailers for any of these vehicles
- tractors, back hoes, bob-cats, earth dozers or front-end loaders
- quad bikes
- go-carts
- buses, trains or trams.

It does not mean a remote control model or toy motor vehicle.

new for old

See page 59.

paraplegia

Permanent and total paralysis of both legs caused by an injury to the spine.

period of insurance

The time you are covered by insurance. It is shown on your Certificate of Insurance.

policy

Your insurance contract. It consists of this PDS and any SPDS we have given you and your latest certificate of insurance.

premium

The amount you pay us for insurance. You also pay stamp duty, GST, any additional government charges and Fire Services Levy (FSL) if applicable.

product disclosure statement (PDS)

PDS is the name of this document and contains some important terms of your insurance cover. It should be read together with your certificate of insurance. If there are materially adverse changes to your PDS, we will send you a Supplementary PDS (SPDS) or a new PDS.

public place

An area open to the public and also includes the common areas of residential units and flats.

quadriplegia

Permanent and total paralysis of both arms and both legs caused by an injury to the spine.

retaining wall

A wall, which is not part of the residential building, designed to hold back or prevent the movement of earth.

set

A group of similar or complementary items that belong or function together.

For example:

- golf clubs are a 'set' (the bag and buggy are separate items)
- a camera 'set' is the camera body, case, standard lens, memory card or stick and standard accessories packaged by the manufacturer, when the camera was new
- a jewellery 'set' is any pendant, charm or brooch, attached to any necklace, bracelet or chain (whether detachable or not) or any pair of earrings or cufflinks.

storm

A violent atmospheric disturbance, producing strong winds. It can be accompanied by rain, lightning, hail or snow.

storm surge

An increase in the sea level caused by a cyclone.

strata or strata title

Strata, group, body corporate, unit or community title.

sum insured

The most you can claim for any one incident. The amount is shown on your certificate of insurance or in this PDS. The sum insured includes GST. The sum insured on your home and contents includes any adjustment to which you are entitled under additional feature 21 (automatic adjustments to the sum insured).

supplementary PDS (SPDS)

A document that updates or adds to the information in the PDS.

tools of trade

Tools or equipment used for any business activity (but not home office equipment).

tsunami

An ocean wave caused by an undersea earthquake or volcanic eruption.

unit

The strata title unit, villa, townhouse or apartment at the insured address. For a non-strata title building, it means a residential flat.

unit building

The strata or unit title building where you own a unit and insure contents in that unit under this policy.

unoccupied and occupied

Unoccupied means:

- the home or unit is not furnished enough to be lived in **or**
- no-one is eating, sleeping and living at the home or unit **or**
- the home or unit is not connected to electrical power.

Occupied means:

- someone is eating, sleeping and living at the home or unit **and**
- the home or unit is connected to electrical power.

Furnished means your home contains at least:

- a bed **and**
- a clothes and linen storage area **and**
- an eating table or bench **and**
- a refrigerator and a cooking appliance.

water containers

- pipes and taps but not agricultural pipes, agricultural hoses or irrigation systems
- roof gutters and rainwater downpipes
- tanks (e.g. water supply tanks, hot water systems, fish tanks)
- swimming pools or spas
- water beds
- dishwashers and washing machines
- baths, sinks, toilets and basins
- drainage and sewerage systems
- water collection trays in freezers, refrigerators and air conditioners.

watercraft

Any vessel designed for use on or in water.

we, us, our

GIO General Limited
ABN 22 002 861 583

what it costs us

- for repairs, it means what it costs us to repair the item.
- for replacement, it means the retail price of the item as if it were new at the time of the loss or damage less any discount available to us.

you and your

The people or entity shown as the insured on your certificate of insurance and these people if they live at the home with you most of the time:

- your spouse, your partner or your de facto
- your brothers and sisters who are not married, or not living with their partner or their de facto
- your parents and parents-in-law
- your children and the children of your partner, your spouse or your de facto.

If you have a complaint

For complaints about this product or our services, please tell the people who provided your initial service. Or you can:

Phone us on	1800 689 762 (FREE CALL)
Fax us on	1300 767 337
Write to us at	Reply Paid 1453 Customer Relations Unit RE058 GPO Box 1453, BRISBANE QLD 4001 or
Email us on	customer.relations@suncorp.com.au

We will try to settle your complaint within **1** working day. If we can't, we will tell you within **3** working days that we have received your complaint and try to settle it within **21** days. For more information on our complaints handling process, please contact us.

If you are dissatisfied with our decision or the way we handled your complaint, please let us know. Otherwise, you can also contact the Financial Ombudsman Service. You need to do this within **2** years of receiving our final decision.

The Financial Ombudsman provides a free service and is a totally independent and impartial body. They will tell you if they can help you, as their services are not available to all customers. If you want more information on the Financial Ombudsman Service, please ask us for a brochure. Their contact details are:

Telephone	1300 780 808 (for the cost of a local call)
Address	GPO Box 3 Melbourne, Victoria 3001
Fax	(03) 9613 6399
Email	info@fos.org.au
Website	www.fos.org.au

Report insurance fraud

Insurance fraud is not a victimless crime. It imposes additional costs on honest policy holders and wastes the valuable resources of our community. This means it affects everyone.

We actively pursue fraudulent and inflated claims in order to keep your premiums as low as possible. Fraudulent claims will be investigated and may be reported to the police.

Help us fight insurance fraud by reporting:

- inflated vehicle or home repair bills
- staged vehicle or home incidents
- false or inflated home or vehicle claims
- home and vehicle fires which may be intentionally started, including by someone known to you.

To report suspected insurance fraud, call 1300 881 725. Let's work together to reduce the impact of insurance fraud on the community.

General Insurance Code of Practice

We support and adhere to the General Insurance Code of Practice.

You can get a copy of the code from the Insurance Council of Australia website (insurancecouncil.com.au) or by phoning (02) 9253 5100.

Financial Claims Scheme

This policy may be a 'protected policy' under the Federal Government's Financial Claims Scheme (FCS) which is administered by the Australian Prudential Regulation Authority (APRA).

The FCS only applies in the extremely unlikely event of an insurer becoming insolvent and the Federal Treasurer making a declaration that the FCS will apply to that insurer.

The FCS entitles certain persons, who have valid claims connected with certain protected policies issued by that insurer to be paid certain amounts by APRA.

Information about the FCS can be obtained from APRA at apra.gov.au or by calling 1300 13 10 60.

This page left blank intentionally

This page left blank intentionally

How to contact us

- › Phone us **24 hours a day – every day**
- › For enquiries **13 10 10**
- › For claims **13 14 46**
- › Report any suspected insurance fraud to our hotline on **1300 881 725**
- › Visit one of our **branches** or **agencies**
- › Find us on the web at **gio.com.au**

Who we are

This insurance is issued by

GIO General Limited
ABN 22 002 861 583
AFSL No. 229873

Level 18
36 Wickham Terrace
Brisbane QLD 4000

